RTU-2



Copyright © 2017–2023 EXFO Inc. All rights reserved. No part of this publication may be reproduced, stored in a retrieval system or transmitted in any form, be it electronically, mechanically, or by any other means such as photocopying, recording or otherwise, without the prior written permission of EXFO Inc. (EXFO).

Information provided by EXFO is believed to be accurate and reliable. However, no responsibility is assumed by EXFO for its use nor for any infringements of patents or other rights of third parties that may result from its use. No license is granted by implication or otherwise under any patent rights of EXFO.

EXFO's Commerce And Government Entities (CAGE) code under the North Atlantic Treaty Organization (NATO) is 0L8C3.

The information contained in this publication is subject to change without notice.

Trademarks

EXFO's trademarks have been identified as such. However, the presence or absence of such identification does not affect the legal status of any trademark.

Where applicable, the Bluetooth[®] word mark and logos are registered trademarks owned by Bluetooth SIG, Inc. and any use of such marks by EXFO Inc. is under license. Where applicable, the MTP[®] mark is a registered trademark of US Conec Ltd. Other third party trademarks and trade names are those of their respective owners.

Units of Measurement

Units of measurement in this publication conform to SI standards and practices.

Patents

The exhaustive list of patents is available at EXFO.com/patent.

Version number: 7.0.0.1

Contents

Regulatory Information	v
1 Introducing the RTU-2	1
Main Features	1
LED Indicators Description	4
Product Registration	6
Technical Specifications	6
Conventions	7
2 Safety Information	9
Other Safety Symbols on Your Unit	11
Laser Safety Information	12
Electrical Safety Information	13
Automatic Fan Speed Management	16
3 Getting Started with Your Unit	17
Preparing for Installation	17
Installing the Optional Access (Junction) Panel	18
Installing Your Unit and the Optional Front Access Panel in a Rack	27
Grounding Your Unit	31
Connecting a Monitoring Device to the Dry Contact Relays	33
Inserting and Removing Test Modules	37
Connecting RTUe-9110/RTUe-9120 External Switches to Your Unit	40
Connecting Your Unit to a Power Source	42
Turning on Your Unit	50
Turning off Your Unit	51
Working With Your Unit for the First Time	54
4 Maintenance	67
Accessing Your Unit Locally	68
Accessing Your Unit Remotely	69
Changing the Administrator Password	70
Upgrading the Firmware	72
Updating Your Unit With Local Firmware	74
Replacing Fuses	77
Recalibrating Your Modules	79
Recycling and Disposal	79

Contents

5 Troubleshooting	81
Solving Common Problems	81
Restoring Your Unit to Normal Operation	83
Accessing the User Documentation	87
Retrieving Logs	88
Contacting the Technical Support Group	90
Transportation	90
6 Warranty	91
General Information	91
Gray Market and Gray Market Products	92
Liability	93
Exclusions	93
Certification	93
Service and Repairs	94
EXFO Service Centers Worldwide	95
Index	97

Regulatory Information

USA Electromagnetic Interference Regulatory Statement

Electronic test and measurement equipment is exempt from FCC part 15, subpart B compliance in the United States of America. However, EXFO Inc. makes reasonable efforts to ensure compliance to the applicable standards.

The limits set by these standards are designed to provide reasonable protection against harmful interference when the equipment is operated in a commercial environment. This equipment generates, uses, and can radiate radio frequency energy and, if not installed and used in accordance with the user documentation, may cause harmful interference to radio communications. Operation of this equipment in a residential area is likely to cause harmful interference in which case the user will be required to correct the interference at his own expense.

Modifications not expressly approved by the manufacturer could void the user's authority to operate the equipment.

Canada Electromagnetic Interference Regulatory Statement

This equipment generates, uses, and can radiate radio frequency energy and, if not installed and used in accordance with the instruction manual, may cause harmful interference to radio communications. Operation of this equipment in a residential area is likely to cause harmful interference.

Cet équipement génère, utilise et peut émettre de l'énergie radio-fréquence et, s'il n'est pas installé et utilisé conformément à la documentation de l'utilisateur, il peut occasionner une interférence néfaste aux communications radio. L'utilisation de cet équipement dans une zone résidentielle est susceptible d'occasionner une interférence néfaste.

Regulatory Information

Caution: This equipment is not intended for use in residential environments and may not provide adequate protection to radio reception in such environments.

Attention : Cet appareil n'est pas destiné à être utilisé dans des environnements résidentiels et peut ne pas assurer la protection adéquate à la réception radioélectrique dans ce type d'environnements.

This is a class A, group 1 product.

Ceci est un produit de classe A, groupe 1.

- **Class A equipment:** Equipment that is, by virtue of its characteristics, highly unlikely to be used in a residential environment, including a home business shall be classified as class A and shall comply with the class A limits specified in the applicable ICES standard. Characteristics considered in this assessment include price, marketing and advertising methodology, the degree to which the functional design inhibits applications suitable to residential environments, or any combination of features that would effectively preclude the use of such equipment in a residential environment.

Classe A : Matériel qui, en raison de ses caractéristiques, ne sera fort probablement pas utilisé dans un milieu domiciliaire ni par des entreprises établies à domicile. Parmi les caractéristiques considérées dans cette évaluation, il y a le prix, les méthodes de commercialisation et de publicité, la mesure dans laquelle les fonctions de l'appareil font qu'il ne se prête pas à des applications convenant au milieu domiciliaire ou toute combinaison de ces caractéristiques qui aurait pour conséquence d'en prévenir effectivement l'utilisation à domicile. Utilisé également pour indiquer les limites d'émission correspondantes qui s'appliquent à un tel matériel.

- **Class B equipment:** Equipment that cannot be classified as Class A shall comply with the Class B limits specified in the applicable ICES standard.

Classe B : Matériel qui ne peut pas être inclus dans la classe A. Utilisé également pour indiquer les limites d'émission correspondantes qui s'appliquent à un tel matériel.

- Group 1 equipment: group 1 contains all equipment which is not classified as group 2 equipment, and includes equipment such as laboratory and scientific equipment, industrial process, measurement and control equipment.

Group 2 equipment: group 2 contains all ISM RF equipment in which radio-frequency energy in the frequency range 9 kHz to 400 GHz is intentionally generated and used or only used locally, in the form of electromagnetic radiation, inductive and/or capacitive coupling, for the treatment of material for inspection/analysis purposes, or for transfer of electromagnetic energy.

Appareils du groupe 1 : le groupe 1 réunit tous les appareils compris dans le domaine d'application de la présente Norme, qui ne sont pas classés comme étant des appareils du groupe 2. Le groupe 1 inclut les appareils scientifiques et de laboratoire, les processus industriels, appareils de mesure ou de contrôle.

Appareils du groupe 2 : le groupe 2 réunit tous les appareils ISM à fréquences radioélectriques dans lesquels de l'énergie à fréquences radioélectriques dans la plage de fréquences comprises entre 9 kHz et 400 GHz est produite et utilisée volontairement ou uniquement utilisée localement sous forme de rayonnement électromagnétique, de couplage inductif et/ou capacitif, pour le traitement de la matière, à des fins d'examen ou d'analyse ou pour le transfert d'énergie électromagnétique.

Supplier's Declaration of Conformity (SDoC)

The SDoC for your product is as follows:

CAN ICES-001 (A) / NMB-001 (A)

EU and UK Electromagnetic Compatibility Regulatory Statement

Warning: This is a class A product. In a domestic environment, this product may cause radio interference in which case the user may be required to take adequate measures. Your product is suitable for use in industrial electromagnetic environments.

Simplified EU and UK Declaration of Conformity

The full text of the declaration of conformity is available at the following Internet address: *www.exfo.com/en/resources/legal-documentation*.

EU Economic Operator

EXFO Solutions SAS
2, rue Jacqueline Auriol,
Saint-Jacques-de-la-Lande,
35091 Rennes Cedex 9
FRANCE

1 **Introducing the RTU-2**

The RTU-2 is a modular remote test unit that can be seamlessly integrated with Nova Fiber Monitoring System (FMS). FMS is the central management software for all EXFO's fiber monitoring probes such as the RTU-2, FG-750, and RTU-2 for point-to-point (P2P) and point-to-multipoint (P2MP) networks.

Main Features

Your unit, which could be part of various EXFO solutions, offers the following:

- Two module slots
- Six USB 3.0 host ports
- LAN/WAN Ethernet port (10/100/1000 Base-T)
- Front and rear management Ethernet ports (10/100/1000 Base-T) for local access
- Installation in 19-inch racks or cabinets (with the provided brackets)
- Possibility to install an optional panel allowing to access the ports and connectors located on the back panel of the unit from the front of the rack instead
- Possibility to use with the RTUe-9110 and RTUe-9120 external switches
- Easy software updates

Introducing the RTU-2

Main Features

Front panel – RTU-2

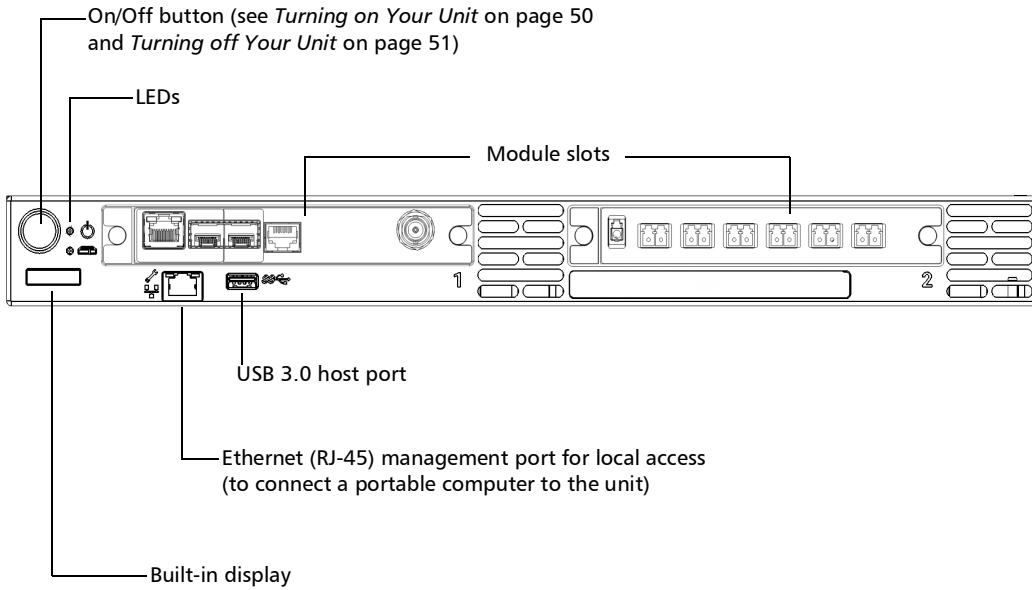

Back panel – RTU-2

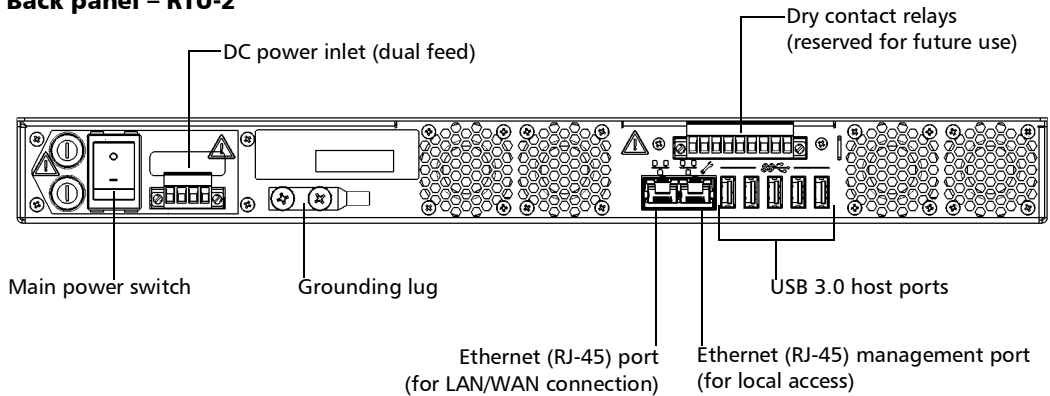

Note: You can also connect the unit to AC power with the AC/DC power adapter sold by EXFO.

Note: Depending on your particular setup needs, you can install an optional panel allowing you to access the ports and connectors of the back panel of the unit from the front of the rack instead. For more information, see *Installing the Optional Access (Junction) Panel on page 18.*

Introducing the RTU-2

LED Indicators Description

Front view – Optional access panel

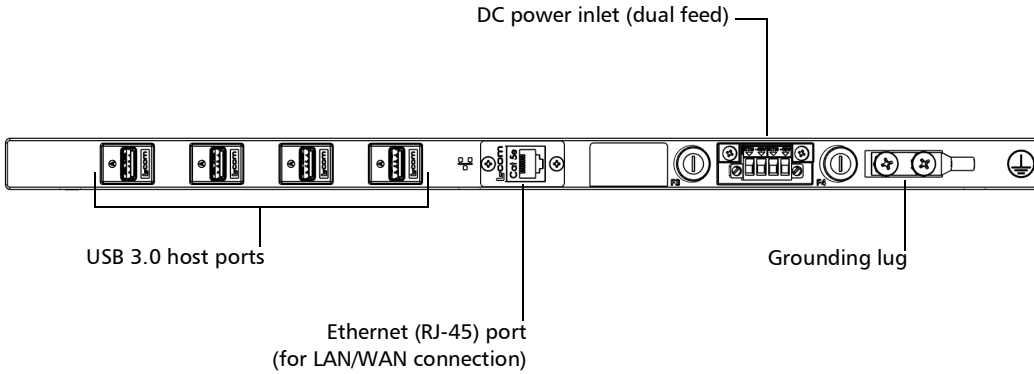



Note: You can also connect the unit to AC power with the AC/DC power adapter sold by EXFO.

LED Indicators Description

There are LED indicators located on the front panel of your unit, providing you with information about the power and system statuses.

The table below presents the possible statuses once the initial startup sequence is complete.

LED	Status	Meaning
 Power	Green	Unit is on.
	Yellow	One of the unit's fuses is blown (see <i>Replacing Fuses</i> on page 77).
	Off	Unit is off.

LED	Status	Meaning
 System ^a	Green	The unit is working properly and is ready.
	Green, blinking	The initialization of the unit or its shutdown is underway.
	Yellow	Non-critical hardware error detected. The temperature of the room where the unit is located could be slightly too low or too high, or there could be a hardware malfunction. Ensure that the temperature falls within the specified operating temperature range (see <i>Electrical Safety Information</i> on page 13). If the problem persists, contact EXFO.
	Red	Critical hardware error detected. The temperature of the room where the unit is located is critically too low or too high, or there could be a hardware malfunction. Ensure that the temperature falls within the specified operating temperature range (see <i>Electrical Safety Information</i> on page 13). If the problem persists, contact EXFO.
	Off	Unit is off.

- a. If more than one error is detected at the same time, the color of the LED will be set according to the most severe error (red as the most severe, followed by yellow).

Product Registration

You can now register your new EXFO products online and benefit from every possible opportunity to optimize their performance. By doing so, you will always be notified of the latest software updates, key product enhancements and up-to-date support information related to your products.

To register your product online:

- 1.** From a computer, open a Web browser and go to www.exfo.com.
- 2.** Log in to your EXFO account.
- 3.** Click **Support > Product registration**.
- 4.** Under **My Products**, click **Register**.
- 5.** Follow the on-screen instructions.

Technical Specifications

To obtain this product's technical specifications, visit the EXFO Web site at www.exfo.com.

Conventions

Before using the product described in this guide, you should understand the following conventions:



WARNING

Indicates a potentially hazardous situation which, if not avoided, could result in *death or serious injury*. Do not proceed unless you understand and meet the required conditions.



CAUTION

Indicates a potentially hazardous situation which, if not avoided, may result in *minor or moderate injury*. Do not proceed unless you understand and meet the required conditions.



CAUTION

Indicates a potentially hazardous situation which, if not avoided, may result in *component damage*. Do not proceed unless you understand and meet the required conditions.



IMPORTANT

Refers to information about this product you should not overlook.

2 **Safety Information**



WARNING

Do not install or terminate fibers while a light source is active. Never look directly into a live fiber and ensure that your eyes are protected at all times.



WARNING

The use of controls, adjustments and procedures, namely for operation and maintenance, other than those specified herein may result in hazardous radiation exposure or impair the protection provided by this unit.



WARNING

If the equipment is used in a manner not specified by the manufacturer, the protection provided by the equipment may be impaired.



WARNING

Use only accessories designed for your unit and approved by EXFO. For a complete list of accessories available for your unit, refer to its technical specifications or contact EXFO.



IMPORTANT

Refer to the documentation provided by the manufacturers of any accessories used with your EXFO product. It may contain environmental and/or operating conditions limiting their use.



IMPORTANT

When you see the following symbol on your unit , make sure that you refer to the instructions provided in your user documentation. Ensure that you understand and meet the required conditions before using your product.



IMPORTANT

When you see the following symbol on your unit , it indicates that the unit is equipped with a laser source, or that it can be used with instruments equipped with a laser source. These instruments include, but are not limited to, modules and external optical units.













IMPORTANT

Other safety instructions relevant for your product are located throughout this documentation, depending on the action to perform. Make sure to read them carefully when they apply to your situation.

Other Safety Symbols on Your Unit

One or more of the following symbols may also appear on your unit.

Symbol	Meaning
	Direct current
	Alternating current
	The unit is equipped with an earth (ground) terminal.
	The unit is equipped with a protective conductor terminal.
	The unit is equipped with a frame or chassis terminal.
	On (Power)
	Off (Power)
 OR 	On/off (Power)
	Fuse

Laser Safety Information

Your instrument is in compliance with standard IEC 60825-1: 2014.



WARNING

Viewing the laser output with telescopic optical instruments (for example, telescopes and binoculars) may pose an eye hazard and thus the user should not direct the beam into an area where such instruments are likely to be used.

The following label indicates that a product contains a Class 1M source:



Laser radiation may be encountered at the optical output port of the modules or instruments that you use with your unit.

Refer to the user documentation of the different modules for the relevant laser safety information.

The modules and instruments that you use with your unit may have different laser classes. Refer to their user documentation for the exact information.

Electrical Safety Information



WARNING

- A readily accessible disconnect device must be installed on the mains (AC or DC circuits). The power cord of the AC/DC power adapter can be considered the disconnect device to the main power.
- If you intend to connect your RTU-2 to AC power, use only the listed and certified AC/DC power adapter provided by EXFO with your unit. It provides reinforced insulation between primary and secondary, and is suitably rated for the country where the unit is sold.
- **DO NOT** connect the unit interfaces metalically to OSP (Outside Plant) wiring. The unit interfaces are designed for use as intra-building surfaces only (Type 2 or Type 4 ports as described in GR-1089-CORE) and require isolation from the exposed OSP cabling. The addition of Primary Protectors is not sufficient protection in order to connect these interfaces metalically to OSP wiring.
- Use only the certified power cord that is suitably rated for the country where the unit is used.
- Replacing detachable MAINS supply cords by inadequately RATED cords may result in overheating of the cord and create a risk of fire.

Safety Information

Electrical Safety Information



WARNING

- Use this unit indoors only.
- Do not remove unit covers during operation.
- Operation of any electrical instrument around flammable gases or fumes constitutes a major safety hazard.
- To avoid electrical shock, do not operate the unit if any part of the outer surface (covers, panels, etc.) is damaged.
- Make sure both disconnect devices are turned off before servicing the unit.
- Only authorized personnel should carry out adjustments, maintenance or repair of opened units under voltage. A person qualified in first aid must also be present. Do not replace any components while the disconnect devices are turned on.
- Use only fuses with the required rated current and specified type (F10A L, 5 mm x 20 mm (0.197 in x 0.787 in), fast-acting, 250 V). Do not use repaired fuses or short-circuited fuse holders. For more information, see the section about replacing the fuses in this user documentation.
- Unless otherwise specified, all interfaces are intended for connection to ES1 circuits only.
- Capacitors inside the unit may be charged even if the unit has been disconnected from its electrical supply.



CAUTION

Position the unit so that the air can circulate freely around it.

Equipment Ratings	
Temperature	
➤ Operation	<ul style="list-style-type: none"> ➤ unit connected to DC power: -5 °C to 50 °C (23 °F to 122 °F) ➤ unit connected to AC power (with AC/DC power adapter): 0 °C to 40 °C (32 °F to 104 °F)
➤ Storage	<ul style="list-style-type: none"> ➤ -40 °C to 70 °C (-40 °F to 158 °F)
Relative humidity ^a	0 % to 95 % non-condensing
Maximum operation altitude	3000 m (9843 ft)
Pollution degree	2
Overvoltage category	I
Measurement category	Not rated for measurement categories II, III, or IV
Input power ^b	<ul style="list-style-type: none"> ➤ unit: -48 V ---; 10 A^c ➤ AC/DC power adapter (units connected to AC power only): 100 - 240 V ~; 50/60 Hz; 5 - 2.5 A

- a. Measured in 0 °C to 31 °C (32 °F to 87.8 °F) range, decreasing linearly to 50 % at 40 °C (104 °F).
 b. Not exceeding ± 10 % of the nominal voltage.
 c. Range: -38.5 - -70 V.



CAUTION

- The use of voltages higher than those indicated on the label affixed to your unit may damage the unit.
- The operation and storage temperatures, as well as the altitude and relative humidity values of some modules may differ from those specified for your unit. In this case, always ensure that you comply with the most restrictive conditions (either module or unit).

Safety Information

Automatic Fan Speed Management

Automatic Fan Speed Management

Your unit will determine the most appropriate fan speed, depending on the power requirements and the type of modules you are using.



IMPORTANT

Fan speed is always determined to cool down the most heat-generating modules.

If the temperature keeps rising and reaches the limit, your unit will turn off to both protect itself and protect the modules it houses.



CAUTION

Make sure to use protective covers over empty slots of your unit to avoid overheating.

3 **Getting Started with Your Unit**

Preparing for Installation



WARNING

- Your unit is designed to be installed in a limited access area, for example, Central Offices, Telecommunication Centers, computer rooms, wiring closet, Outside Plant/CELL-Site class 1, and similar type locations and in accordance with local codes.
- Only trained personnel can perform the unit installation and configuration tasks. These people have appropriate technical training and experience to be aware of the hazards to which a person can be exposed when performing these installation tasks.



IMPORTANT

To ensure compliance with GR-1089-CORE, use only shielded cables for Ethernet connections to the unit. The shielded cables must be grounded at both ends.

Before installing your unit, you should take the following into consideration:

- The chosen location provides adequate clearance for maintenance procedures.
- The location is an environmentally-controlled area that meets the minimum operating parameters.
- The location is isolated from strong electromagnetic fields produced by electrical devices.
- The power cable and power supply are compatible with your power service.
- The power source is properly grounded and falls within the internal power supply rating.

Getting Started with Your Unit

Installing the Optional Access (Junction) Panel

Installing the Optional Access (Junction) Panel

Depending on your particular setup needs, you can install an optional panel allowing you to access the ports and connectors of the back panel of the unit from the front of the rack instead.



WARNING

For your safety and to avoid damaging your RTU-2 unit, always ensure that the disconnect devices to which the unit will be connected are turned off until you have completed all the installation procedures.

The optional access panel kit includes the following:

- Access panel assembly itself
- Cable retainer
- Cover
- Two mounting brackets (left and right)
- Four USB cables
- One Ethernet cable
- Four M3 x 8 pan-head (#1054071) screws
- Four M3 x 4 pan-head (#1044122) screws
- Eight M4 x 8 flat-head (#1052740) screws
- Three M3 x 5 flat-head (#1067832) screws
- One 80 mm x 2.3 mm (#1001051) cable tie

To install the optional access panel:

1. Ensure that your RTU-2 unit is turned off.



CAUTION

You should remove all your modules from the RTU-2 unit before installing the access panel. Otherwise, they could be damaged or their calibration could be affected.

2. Ensure that no USB or electrical cables are connected to the RTU-2.
3. Position the RTU-2 so that its *top* panel rests on a flat surface such as a table.
4. Install the mounting brackets as follows:
 - 4a. Align the holes of the first bracket with the holes of the unit's casing so that the mounting flange of the bracket is positioned 18 mm from the front panel of the RTU-2.

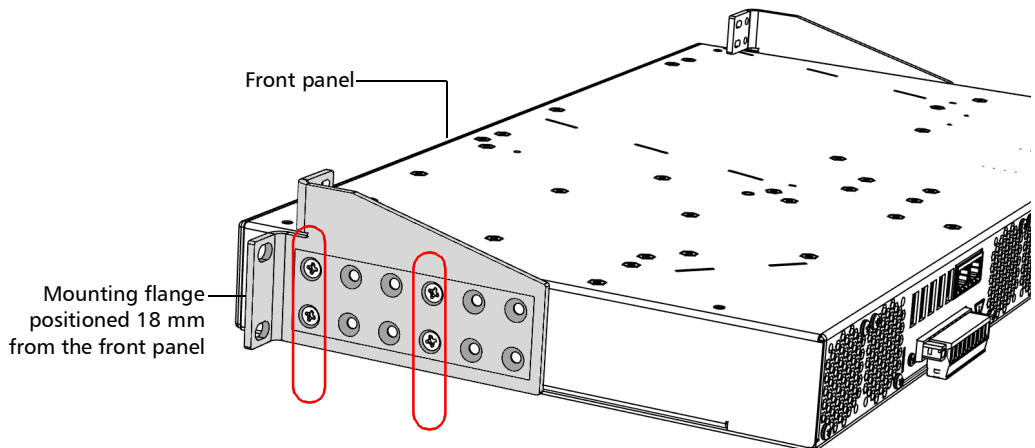

- 4b. Fix the first bracket on the unit with four M4 x 8 flat-head (#1052740) screws.

Getting Started with Your Unit

Installing the Optional Access (Junction) Panel

- 4c.** Repeat steps 3b and 3c with the other bracket, ensuring that you place the bracket at the exact same position (set of holes on the bracket and on the unit's casing).
- 5.** Attach the access panel as follows:
 - 5a.** Place the access panel (shown in gray below) on the RTU-2 so that the screw holes for the cover are visible. Ensure that the access panel is positioned *in front of* the mounting bracket legs.

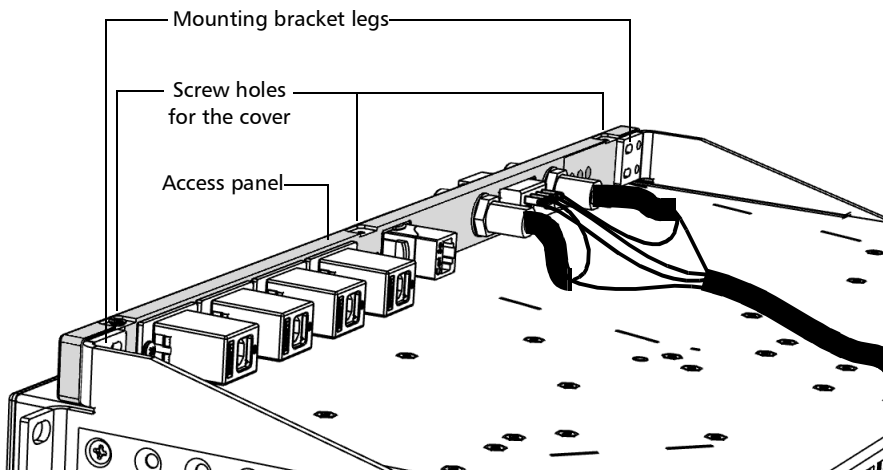

- 5b.** Fix the access panel to the *round* screw holes of the first bracket leg with two M3 x 8 pan-head (#1054071) screws.

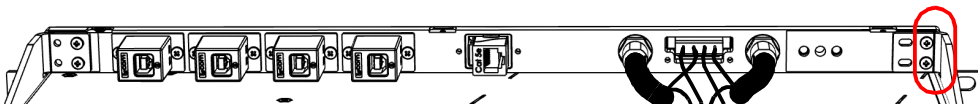

- 5c.** Fix the access panel to the *slotted* screw holes of the second bracket leg with two M3 x 8 pan-head (#1054071) screws.

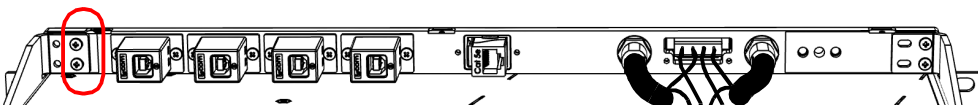



IMPORTANT

For a cleaner installation and easier maintenance, EXFO recommends to connect the USB cables as suggested below.

6. Connect the USB and Ethernet cables as follows:

6a. Connect the straight part of the USB cables to the corresponding ports located at the back of the access panel (number 1 represents the first USB cable).

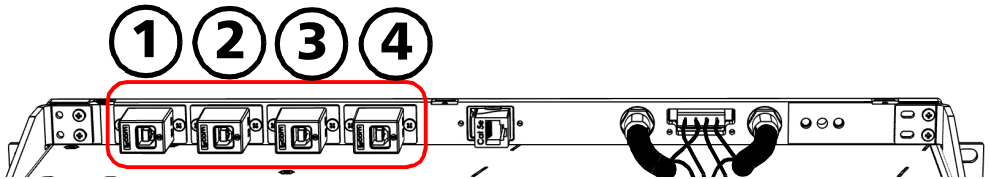

6b. Connect the straight part of the Ethernet cable to the corresponding port located at the back of the access panel.

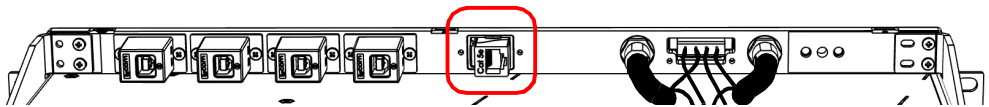

6c. Connect the angled part of the USB cables to one of the corresponding ports located at the back of the RTU-2.

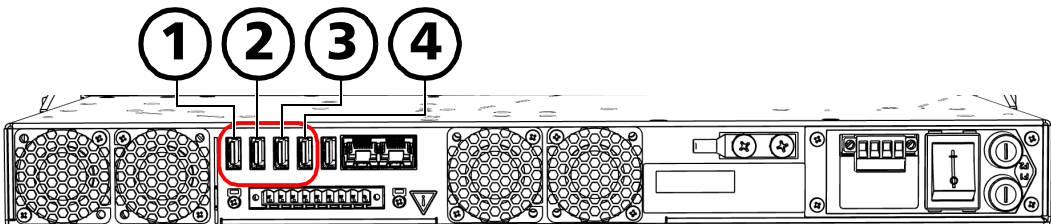

Getting Started with Your Unit

Installing the Optional Access (Junction) Panel

- 6d.** Connect the angled part of the Ethernet cable to the LAN/WAN Ethernet port () located at the back of the RTU-2.

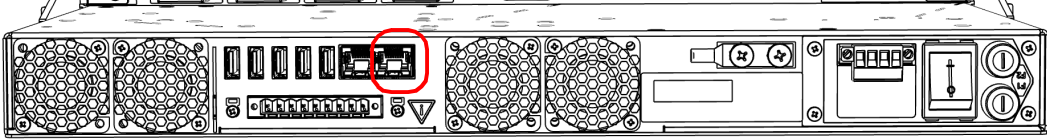

- 7.** Move the grounding lug as follows:

- 7a.** Remove the two Phillips screws and the grounding lug from the back panel of the RTU-2.

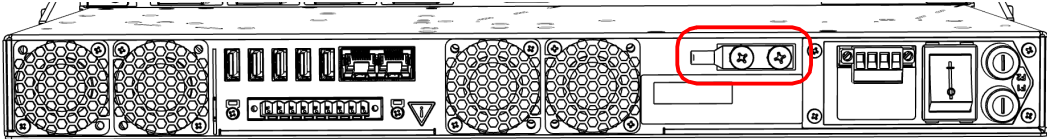

- 7b.** Place the assembly so that you can see the front of the access panel.

- 7c.** If you are ready to ground the unit, see *Grounding Your Unit on page 31*.

OR

If you prefer to ground the unit later, use the two Phillips screws to attach the grounding lug to the front of the access panel.

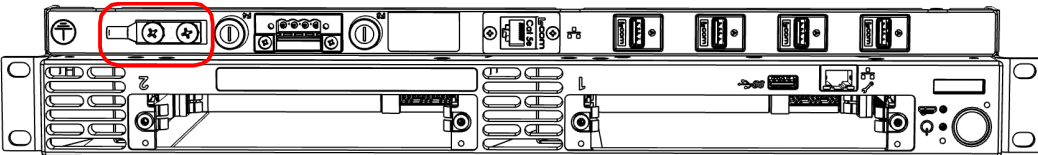

Getting Started with Your Unit

Installing the Optional Access (Junction) Panel

8. Ensure that the RTU-2 is not already equipped with a terminal block and if so, remove it as follows:
 - 8a. Place the assembly so that you can see the back panel of the RTU-2.
 - 8b. Unscrew the two screws holding the terminal block in place.

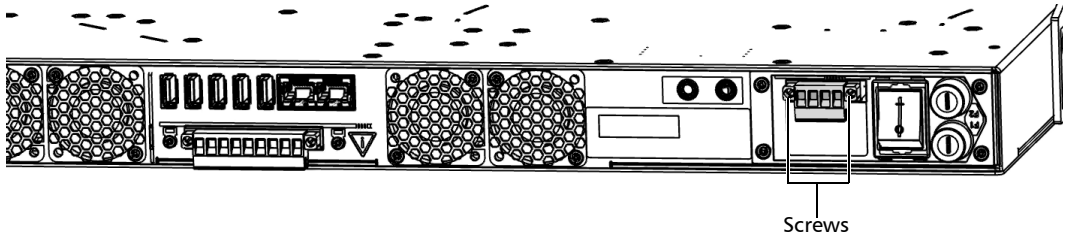

- 8c. When the terminal block is loose, gently pull it toward you to remove it, and expose the electrical connectors. You can discard this terminal block as you will no longer need it.

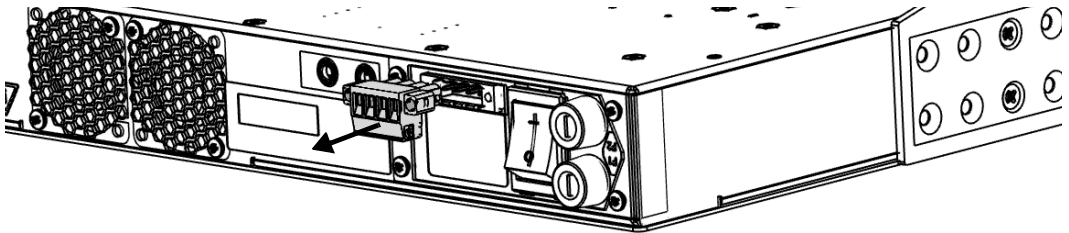

Note: *If no terminal block was attached to the RTU-2 at time of purchase, but one was provided separately in a bag, you can simply discard this terminal block as you will not need it.*

Getting Started with Your Unit

Installing the Optional Access (Junction) Panel

9. Prepare the access panel for power connection as follows:
 - 9a. Position the power cable of the access panel so that its connector is aligned properly with the bay containing the electrical connectors of the RTU-2.

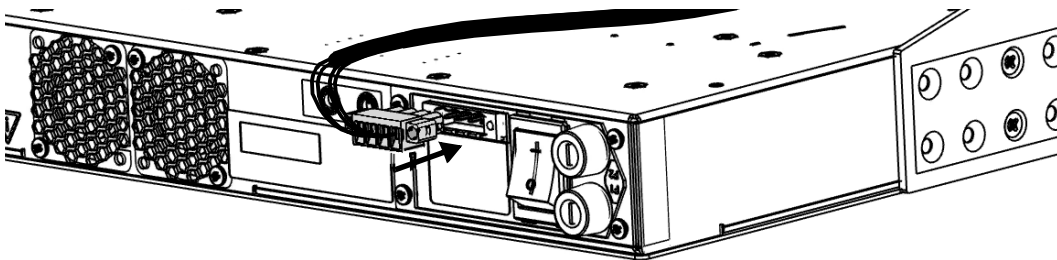

- 9b. Slide the connector all the way into the bay until it stops.
- 9c. Secure the connector in place with the two screws.
- 9d. If you are ready to make the connections for AC or DC power, see *Connecting Your Unit to a Power Source on page 42*.

OR

If you prefer to make these connections later, go to next step.

Getting Started with Your Unit

Installing the Optional Access (Junction) Panel

10. Install the cable retainer as follows:

10a. Position the cable retainer as shown below, ensuring that the power cable is well aligned with the notch for the cable tie.

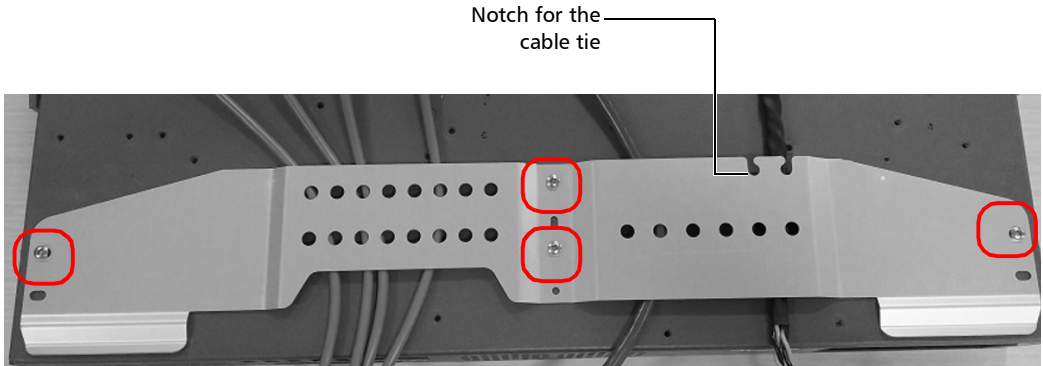

10b. Fix the cable retainer with four M3 x 4 pan-head (#1044122) screws.

11. Secure the power cable with the 80 mm x 2.3 mm (#1001051) cable tie, as shown below. Once the power cable is secured, cut off the excess length of the cable tie. Otherwise, you will not be able to install the cover later.

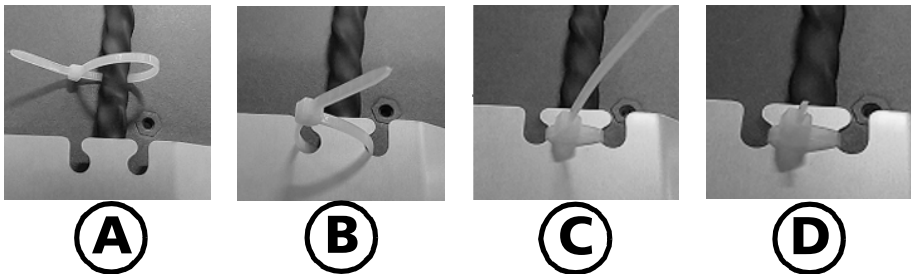

Getting Started with Your Unit

Installing the Optional Access (Junction) Panel

12. Install the cover on the access panel as follows:

12a. From the back of the access panel, slide the cover forward until it clips onto the cable retainer.

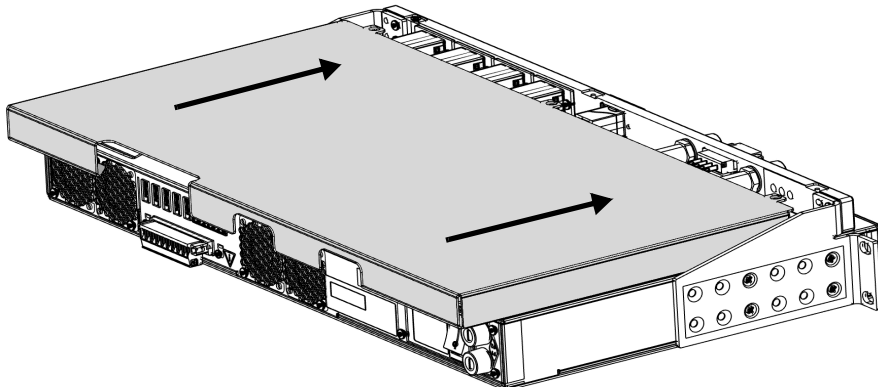

12b. Secure the cover in place with three M3 x 5 flat-head (#1067832) screws.

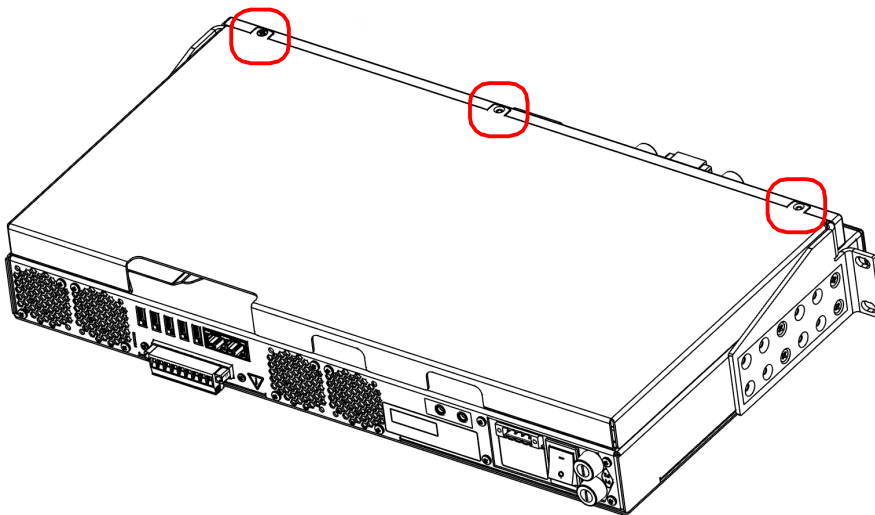

The access panel is now installed properly and ready to use.

Installing Your Unit and the Optional Front Access Panel in a Rack

- Your unit and its optional front access panel are designed to be installed in 19-inch racks only with the provided mounting brackets. They will not fit into 21-inch (ETSI) and 23-inch racks.
- The rack should provide sufficient vertical clearance to insert the unit and the front access panel (if applicable).
 - The height of the unit alone is one rack unit (1U) high or 44,45 mm (1.75 in.).
 - The total height of the unit and the front access panel is one and a half rack unit (1.5U) high or 66,68 mm (2.63 in.).
- Your unit has front air intakes and rear air exhausts. Mount or position your unit so that air can circulate freely around it. When operating the unit, select a location that provides at least:
 - 75 mm (3 in.) of clearance at the rear
 - 75 mm (3 in.) of clearance on the front



CAUTION

Failure to provide adequate cooling clearance may result in an excessive internal temperature, thus reducing the reliability of your RTU-2 unit.

Note: *There is no need to leave an empty slot between units when you stack them one on top of the other inside a rack.*

Getting Started with Your Unit

Installing Your Unit and the Optional Front Access Panel in a Rack



WARNING

- The equipment rack must be anchored to an unmovable support to prevent it from falling over when one or more units are extended in front of the rack on slides. You must also consider the weight of any other device installed in the rack. A crush hazard exists if the rack tilts forward, which could cause serious injury.
- Mounting of the unit in a rack or cabinet should be such that a hazardous condition is not achieved due to uneven mechanical loading.



IMPORTANT

Unless you intend to use an optional access panel, to let the front USB and management ports free for potential maintenance, EXFO recommends to keep all non-optical connections to the back of the unit.

To install your unit in a rack:

1. Ensure that your unit is turned off.



CAUTION

You should remove all your modules from the RTU-2 unit before installing it into a rack. Otherwise, they could be damaged or their calibration could be affected.

2. Ensure that no USB or electrical cables are connected to the unit.

Getting Started with Your Unit

Installing Your Unit and the Optional Front Access Panel in a Rack

3. If you are using the unit without the optional access panel, install the mounting brackets as follows:
 - 3a. Position the unit so that its bottom panel rests on a flat surface such as a table.
 - 3b. Align the holes of the first bracket with the holes of the unit's casing at the position that best suits your installation needs. You can even invert position of the mounting bracket if necessary.

Brackets in standard position

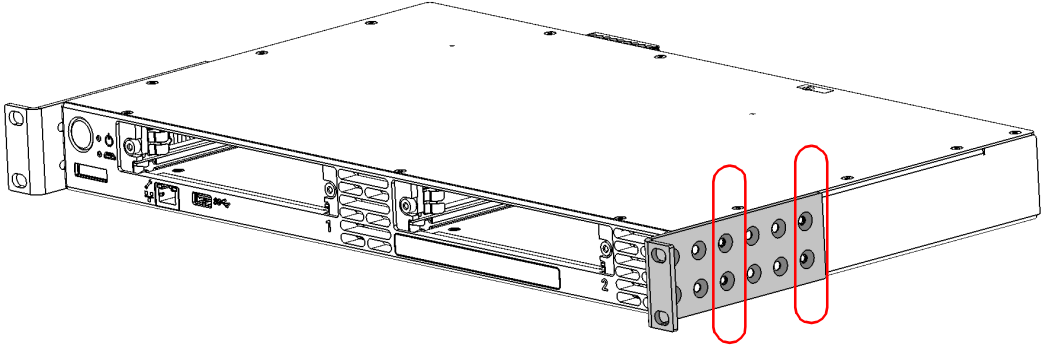

Brackets in inverted position

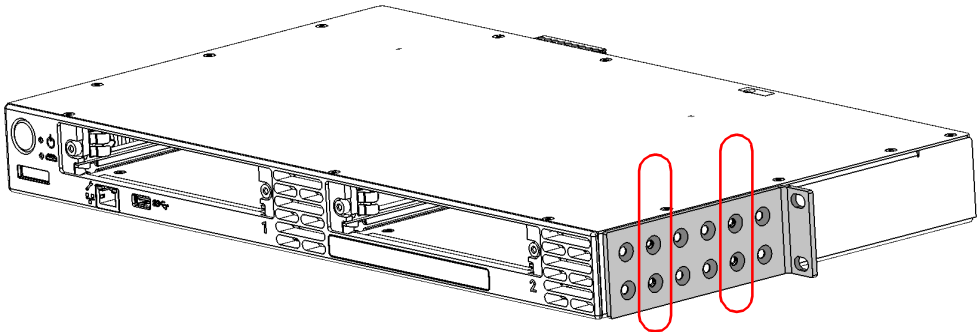

Getting Started with Your Unit

Installing Your Unit and the Optional Front Access Panel in a Rack

- 3c.** Fix the first bracket on the unit with the supplied screws (four screws per bracket).
- 3d.** Repeat steps 3b and 3c with the other bracket, ensuring that you place the bracket at the exact same position (orientation of the bracket, set of holes on the bracket and on the unit's casing).
- 4.** Place the unit in the rack at the desired height.
- 5.** Fix the unit in place using the hardware supplied with the rack. Use two screws per side.

To ground your unit properly, you must ensure that there is a metal-to-metal contact between the rack and the mounting hardware. For this reason, EXFO recommends to use thread-forming screws, star (tooth) lock washers, or similar hardware that remove any paint or non-conductive coatings. For more information, see *Grounding Your Unit* on page 31.

RTU-2 without access panel

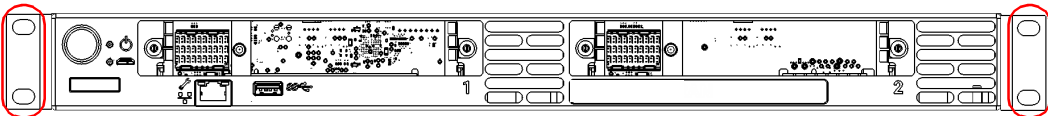

RTU-2 with access panel

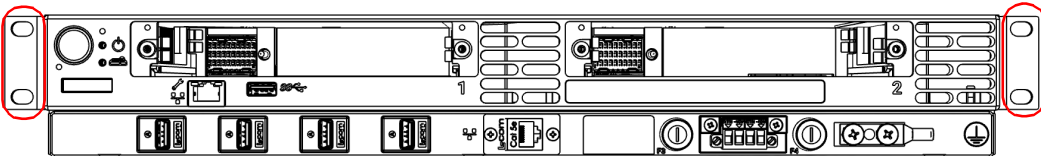

Grounding Your Unit

To avoid the potential for an electrical shock hazard, you must reliably connect an earth grounding conductor to the unit or to the optional front access panel if you are using one.

Note: *The DC units are intended for installation with an isolated DC return (DC-I) and are to be installed in a Common Bonding Network (CBN) per GR-1089-CORE.*



WARNING

All wiring and installation must be in accordance with local building and electrical codes acceptable to the authorities in the countries where the equipment is installed and used.

If you are not sure on how to proceed, consult a certified electrician.

Getting Started with Your Unit

Grounding Your Unit

To ground your unit:

1. Remove the two Phillips screws and the grounding lug from the back panel of your unit or from the front of the optional access panel if you are using one.

Back panel – RTU-2

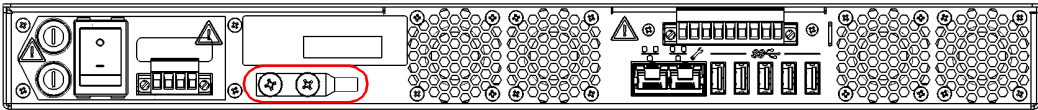

Front view – Optional access panel

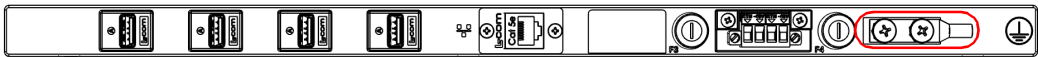

2. Prepare the ground wire (#14 AWG, green), and attach one of its ends to the unit's or access panel's grounding lug using a crimping tool.
3. Use the two Phillips screws to attach the grounding lug and wire assembly to the back panel of your unit or to the front of the optional access panel.
4. Ground the other end of the wire as per your local regulation.

Your unit is now grounded properly.

Connecting a Monitoring Device to the Dry Contact Relays

Your unit is equipped with dry contact relays that enable you to connect your own monitoring device if you wish to do so.

There are three dry contact relays (max. \approx 60 V; 0.46 A) on the back panel of the unit:

- Application relay (reserved for future use): Configurable by an application for a specific task.
- Power relay: Activated when all components related to the unit are powered on (the power LED is lit and does not blink).
- System relay: Activated when all the system components are working normally (the system LED is green).



CAUTION

For optimum performance and safety, you must either crimp a terminal (ferrule) onto the stranded conductors, or tin them before installing them in the terminal block.

Getting Started with Your Unit

Connecting a Monitoring Device to the Dry Contact Relays

To connect a monitoring device to the dry contact relays:

1. Unscrew the two screws holding the terminal block for dry contact relays in place.

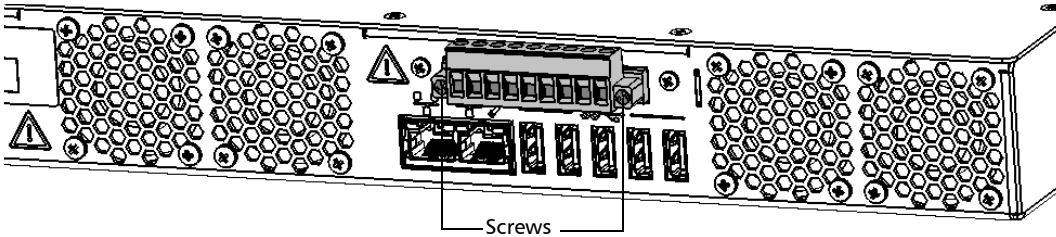

2. When the terminal block is loose, gently pull it toward you to remove it, exposing the pins.

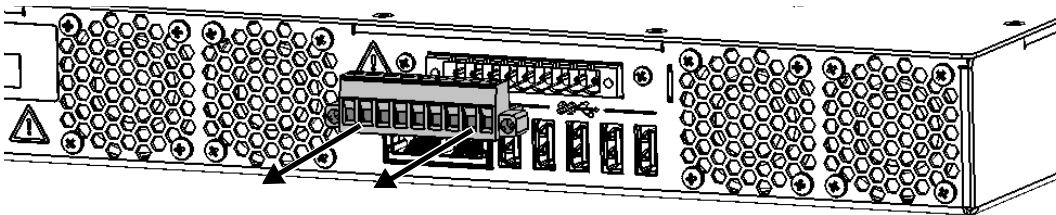

3. Crimp each wire with a terminal (ferrule) or tin each of them.
4. Unscrew the screws (shown in grey) located at the top of the terminal block.

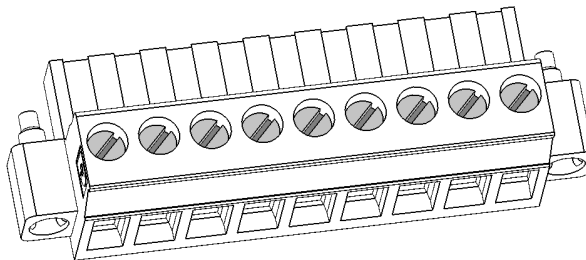

Getting Started with Your Unit

Connecting a Monitoring Device to the Dry Contact Relays

5. Connect the wires using the diagram below as a guide.

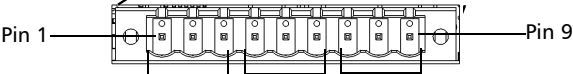
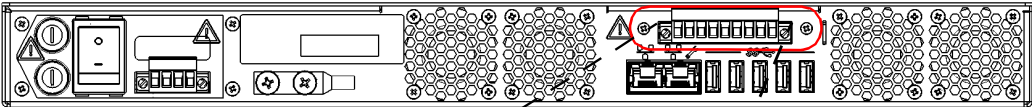

Power relay

- Pin 1 - NO = Normally open
- Pin 2 - C = Common
- Pin 3 - NC = Normally closed

Application relay

- Pin 7 - NO = Normally open
- Pin 8 - C = Common
- Pin 9 - NC = Normally closed

System relay

- Pin 4 - NO = Normally open
- Pin 5 - C = Common
- Pin 6 - NC = Normally closed

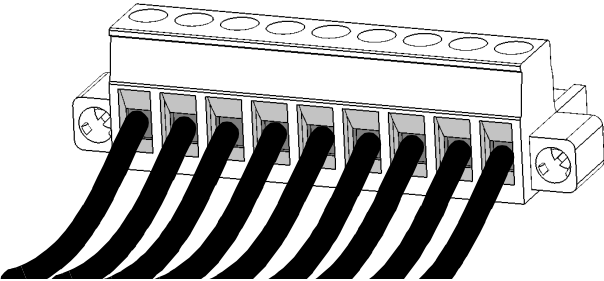

6. Tighten the screws located at the top of the terminal block to secure the wires in place.

Getting Started with Your Unit

Connecting a Monitoring Device to the Dry Contact Relays

7. Ensure that the terminal block is aligned properly with the bay containing the pins.

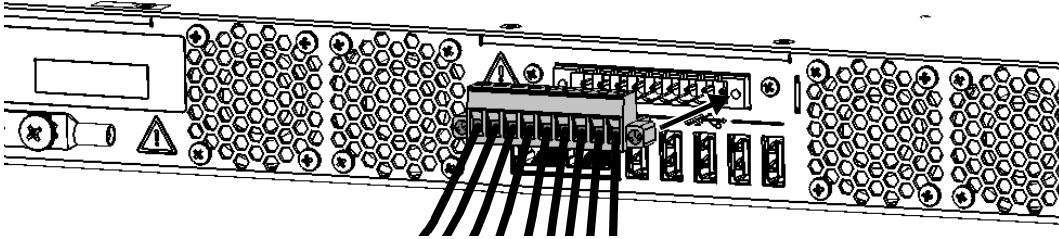

8. Slide the terminal block all the way into the bay until it stops.
 9. Screw the two screws to secure the terminal block in place.
- The dry contact relays are now installed properly.

Inserting and Removing Test Modules



CAUTION

- Never insert or remove a module while the RTU-2 unit is turned on. This will result in immediate and irreparable damage to both the module and unit.
- To avoid damaging your unit, use it only with modules approved by EXFO.

To insert a module into the unit:

1. If it is not already done, turn off your unit by pressing the on/off button.
2. Insert the protruding edges of the module into the grooves of the receptacle's module slot.
3. Push the module all the way to the back of the slot, until it stops.
4. Turn the two retaining screws clockwise until they are tightened to secure the module into its "seated" position. The faceplate of the module should be flush with the front panel of the unit.

Note: *If you have not connected to the Nova Fiber Web application and performed the complete configuration of your unit yet, just disregard step 5 and the rest of the current procedure. The necessary steps will be explained in the section about using your unit for the first time.*

5. Turn on the unit by pressing the on/off button. The module will be detected automatically during the startup sequence.
6. Using the Nova Fiber Web application, from the **Status** window, confirm that the detection of the module is completed.
7. Connect the optical fibers as needed.

Getting Started with Your Unit

Inserting and Removing Test Modules

- 8.** From FMS, proceed as follows:
 - 8a.** If the RTU-2 unit was already attached before you inserted a module, detach it.
 - 8b.** Attach the RTU-2 unit hosting the newly inserted module.
 - 8c.** Perform an on-demand test as needed to confirm that all the fibers have been properly connected.
 - 8d.** Configure optical routes as needed.

Note: *For more information about FMS, refer to its user documentation.*

To remove a module from the unit:

- 1.** Turn off your unit by pressing the on/off button.
- 2.** Disconnect any optical fibers.
- 3.** Turn the two retaining screws counterclockwise until they are loose (do not remove them completely).

4. Hold the module by its sides or by the retaining screws (*NOT by the optical connectors*) and pull it out.

Note: *The retaining screws can be used as handles to pull out the module safely.*



CAUTION

Pulling out a module by its optical connectors could seriously damage both the module and connectors. Always pull out a module by its casing or the retaining screws.

5. Cover empty slots with the supplied protective covers.



CAUTION

Failure to reinstall protective covers over empty slots will result in ventilation problems.

6. Turn on the unit by pressing the on/off button.
7. Using the Nova Fiber Web application, from the **Status** window, confirm that the removal of the module is completed.
8. Reconnect the optical fibers as needed.

Getting Started with Your Unit

Connecting RTUe-9110/RTUe-9120 External Switches to Your Unit

9. From FMS, proceed as follows:
 - 9a. If the RTU-2 unit was already attached before you removed a module, detach it.
 - 9b. Attach the RTU-2 unit from which you have just removed a module.
 - 9c. Perform an on-demand test as needed to confirm that all the fibers have been properly reconnected.
 - 9d. Reconfigure optical routes as needed.

Note: For more information about FMS, refer to its user documentation.

Connecting RTUe-9110/RTUe-9120 External Switches to Your Unit

Depending on your testing needs, you may want to connect external switches to your unit to increase the number of optical ports available.

If you want to remove an external switch from the system, ensure that no test is underway, and then simply disconnect the optical fibers and the USB cable.

Note: Once you have connected or disconnected an external switch, you need to update your test setup in FMS. You must first detach and reattach the corresponding RTU-2 unit, and then select the desired switch and ports when applicable. For more information on how to attach or detach units, refer to the user documentation of FMS.



IMPORTANT

Unless you intend to use an optional access panel, if you work with an RTUe-9110, to let the front USB and management ports free for potential maintenance, EXFO recommends to keep all non-optical connections to the back of the unit.

Getting Started with Your Unit

Connecting RTUe-9110/RTUe-9120 External Switches to Your Unit

To connect a single switch to your unit:

1. Connect the provided USB cable to the USB port (B type) located on the back panel (RTUe-9110) or on the front panel (RTUe-9120) of the switch.

RTUe-9110 – Back panel

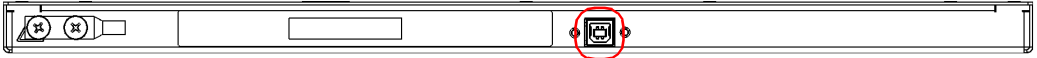

RTUe-9120 – Front panel



2. Connect the other end of the USB cable to one of the USB ports located on the back panel of the unit or on the front of the optional access panel.

Back panel – RTU-2

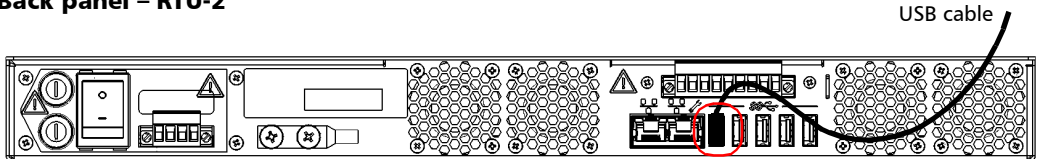

Front view – Optional access panel

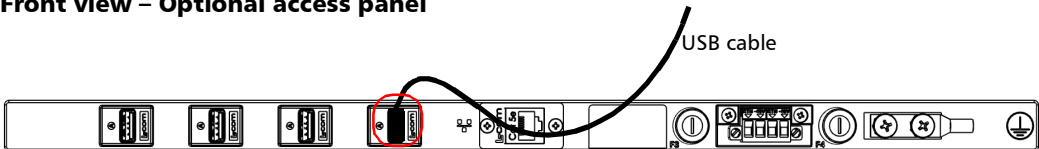

Note: For more information on how to connect several switches to your unit, refer to the *Optical Switch user guide*.

Getting Started with Your Unit

Connecting Your Unit to a Power Source

Connecting Your Unit to a Power Source

Before starting to work with your unit, you must connect it to a power source (AC or DC). There is a specific procedure for each of these types of power sources.



WARNING

- ▶ A certified over-current protecting device that is suitably rated must be installed at the source.
- ▶ All electrical installation and accessories must be done and selected as per local electrical code and regulation.
- ▶ To avoid fire hazards and ensure your safety, when you intend to connect your unit to DC power, always select a wire gauge according to the RTU-2 unit's ratings, cable length, and local electrical code.



CAUTION

- ▶ For optimum performance and safety, you must either crimp a terminal (ferrule) onto the stranded conductors, or tin them before installing them in the terminal block.
- ▶ To avoid damaging your unit, always ensure that the disconnect devices to which the unit will be connected are turned off before connecting it to DC or AC power.

Note: *The AC/DC power adapter is not covered by the NEBS certification.*

To connect your unit to DC power:

1. If you are not using the optional access panel, ensure that the unit's main power switch is in the off position.

Back panel

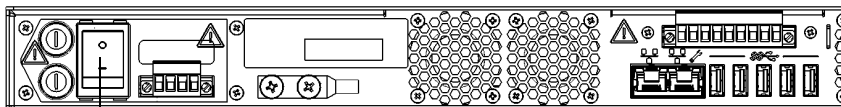

Main power switch in off position

2. Ensure all power is off or disconnected at the source.

Note: *A certified over-current protection of 10 A must be installed at the power secondary distribution.*

3. Ensure that the unit is grounded properly. For more information, see *Grounding Your Unit* on page 31.

Getting Started with Your Unit

Connecting Your Unit to a Power Source

4. From the back panel of your unit or the front of the optional access panel, unscrew the two screws holding the terminal block in place.

Back panel – RTU-2

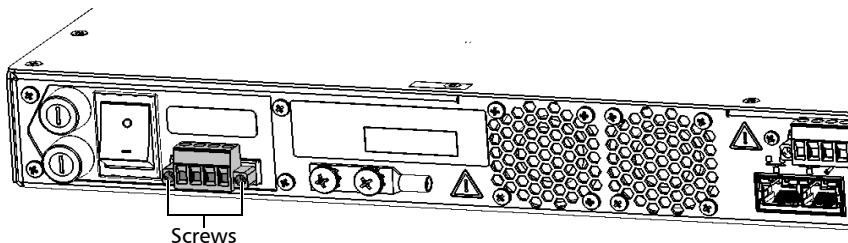

Front view – Optional access panel

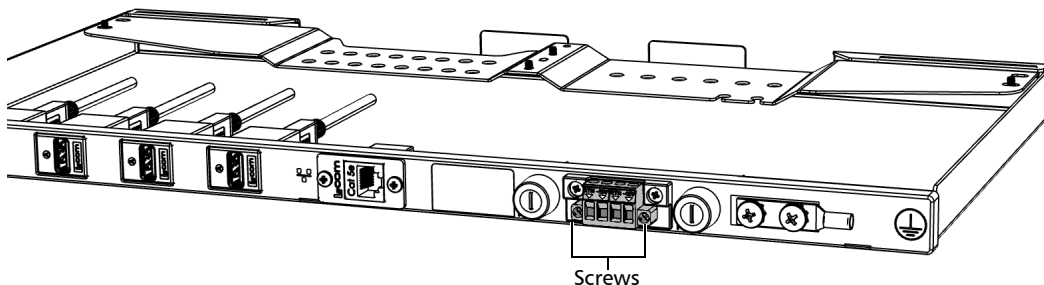

5. When the terminal block is loose, gently pull it toward you to remove it, exposing the electrical connectors.

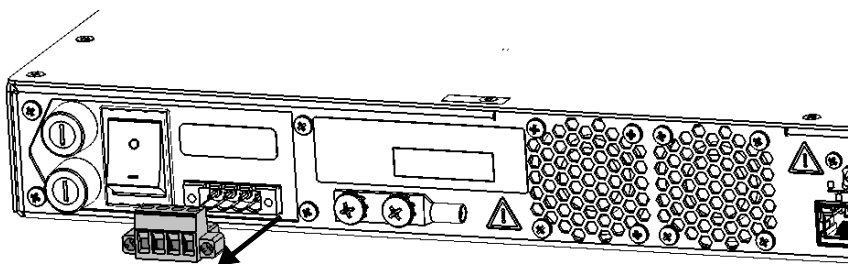

Getting Started with Your Unit

Connecting Your Unit to a Power Source

6. Crimp each power lead (maximum 14 AWG) with a terminal (ferrule) or tin each of them. Unscrew the four screws (shown in grey) located at the top of the terminal block.

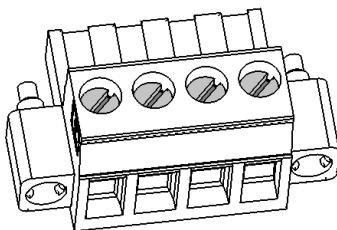

7. Pair the power leads with the appropriate power terminal for each of the feed, respecting the polarity as indicated just above the terminal block (unit) or on the terminal block (optional access panel).

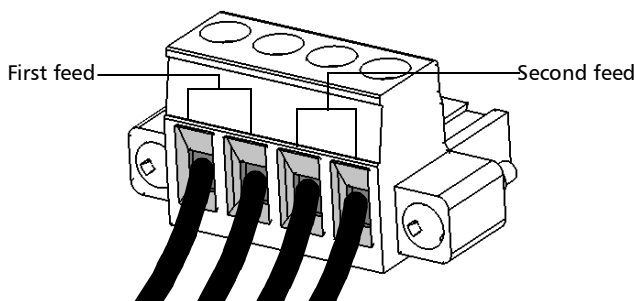
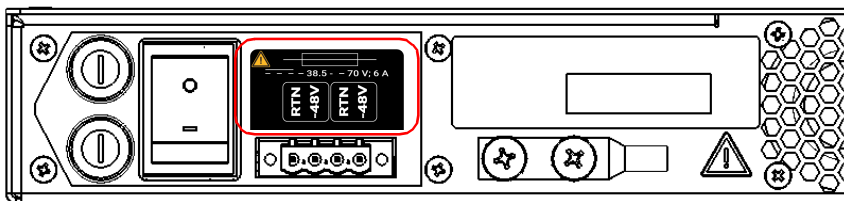

Getting Started with Your Unit

Connecting Your Unit to a Power Source

8. Tighten the four screws located at the top of the terminal block to secure the wires in place.
9. Ensure that the terminal block is aligned properly with the bay containing the electrical connectors.

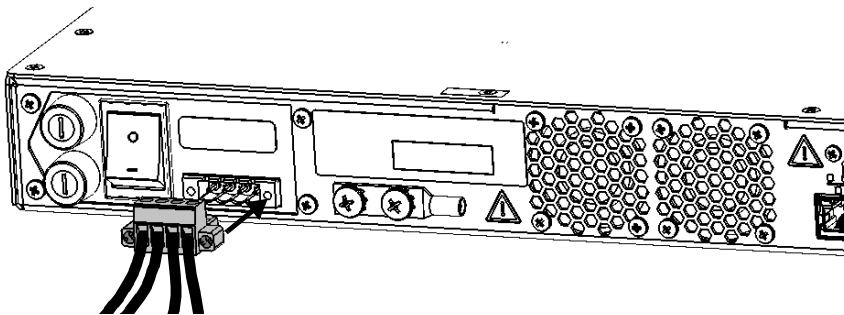

10. Slide the terminal block all the way into the bay until it stops.
11. Screw the two screws to secure the terminal block in place.
12. Turn on the disconnect device that is connected to the unit or to the optional access panel.
13. If you are not using the optional access panel, flip the unit's main power switch to the on position.

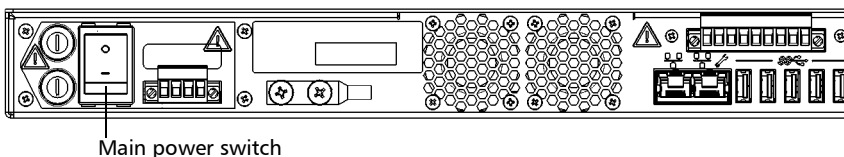

You are now ready to turn on the unit (see *Turning on Your Unit* on page 50).

To connect your unit to AC power:

1. If you are not using the optional access panel, ensure that the unit's main power switch is in the off position.

Back panel

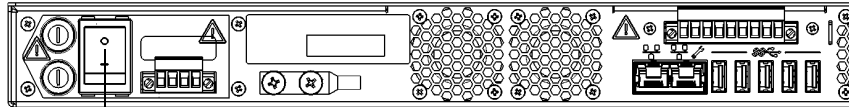

Main power switch in off position

2. Ensure all power is off or disconnected at the source.
3. Ensure that the unit is grounded properly. For more information, see *Grounding Your Unit* on page 31.

Getting Started with Your Unit

Connecting Your Unit to a Power Source

4. If necessary, remove the block terminal as follows:
 - 4a. From the back panel of your unit or the front of the optional access panel, unscrew the two screws holding the terminal block in place.

Back panel – RTU-2

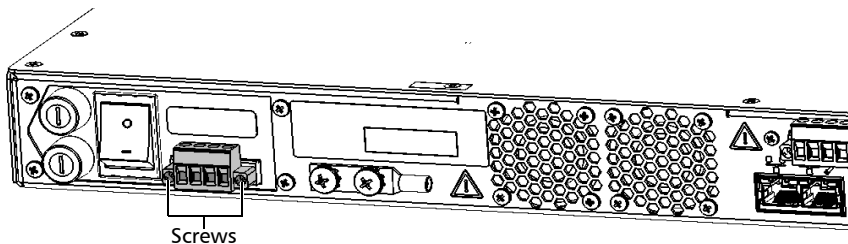

Front view – Optional access panel

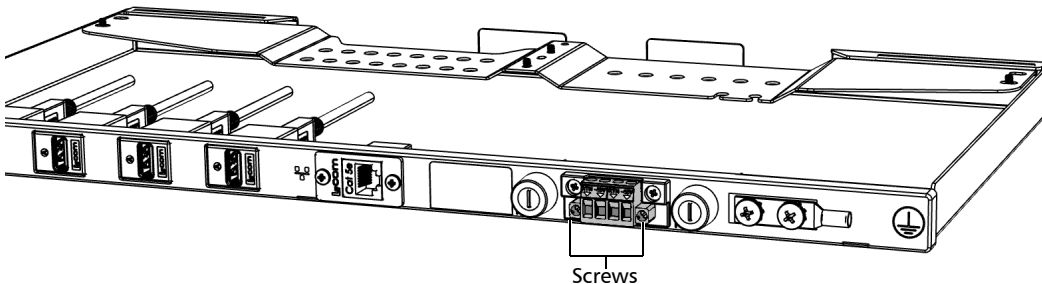

- 4b. When the terminal block is loose, gently pull it toward you to remove it, exposing the electrical connectors.

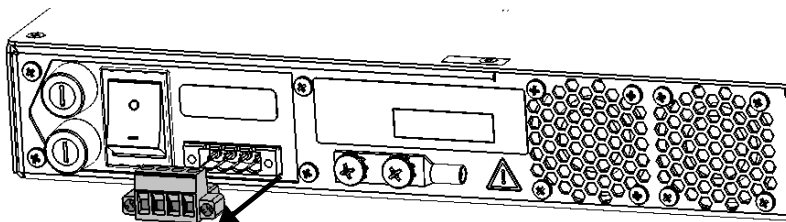

Getting Started with Your Unit

Connecting Your Unit to a Power Source

5. Ensure that the connector of the AC/DC power adapter is aligned properly with the bay containing the electrical connectors.

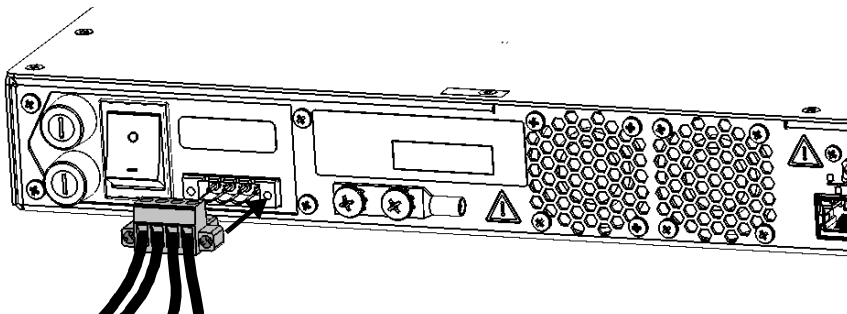

6. Slide the connector of the AC/DC power adapter all the way into the bay until it stops.
7. Screw the two screws to secure the connector of the AC/DC power adapter in place.
8. Ensure that the removable power cord is connected to the other end of the AC/DC power adapter, and then connect the adapter to the power outlet.
9. If necessary, turn on the disconnect device.
10. If you are not using the optional access panel, flip the unit's main power switch to the on position.

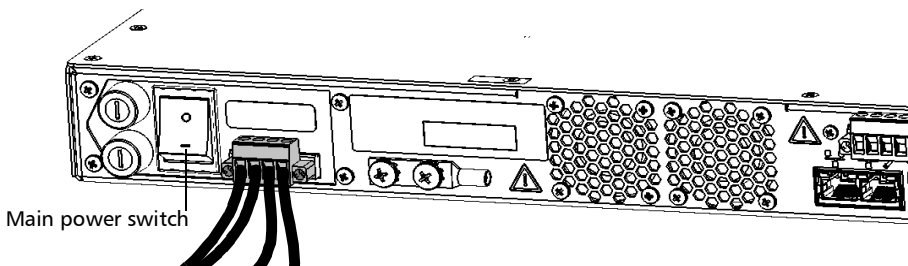

You are now ready to turn on the unit (see *Turning on Your Unit* on page 50).

Getting Started with Your Unit

Turning on Your Unit

Turning on Your Unit

Before you turn on the unit for the very first time, EXFO recommends that you read the safety and installation instructions, including how to connect the unit to AC or DC power.

To turn on the unit:

1. If it is not already done, connect your unit to an AC or a DC power source (see the corresponding section for safety information and detailed instructions).
2. If it is not already done, ensure that the main power switch, located at the back of your unit is set to the on position.

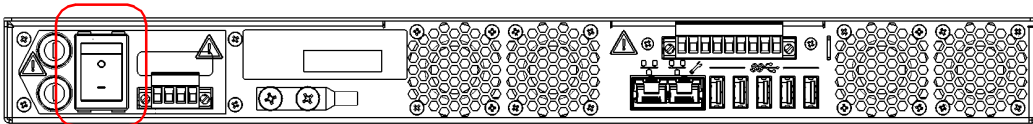

3. Press the on/off button. For more information about working with your unit for the very first time, see the corresponding section in this documentation.

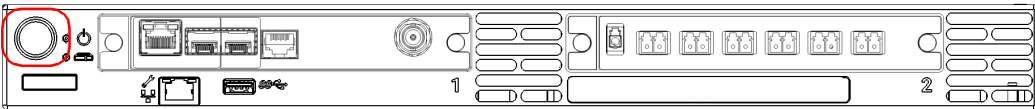

Turning off Your Unit

Your unit will shut down when you press the power button. It will perform a complete restart routine the next time you use it, and start in Windows.

Note: *Should the unit ever stop responding, first try to turn it off normally. If this does not work, if you can, flip the main power switch (located at the back of the unit) to the off position, and then flip it back to the on position. If you do not have access to the main power switch, turn off the disconnect devices to which the unit is connected.*

In the event of a power outage, your unit is configured to automatically return to the state into which it was before the outage (on or off). This means that if your unit was on before the outage, it will automatically restart when the power comes back.



CAUTION

To avoid damaging your unit when you need to disconnect it from its external power source, first turn the unit off. Then, turn off the disconnect devices to which the unit is connected before proceeding.

To turn off the unit completely from the unit itself:

Press the on/off button.

5. From the list, select **Administration**.

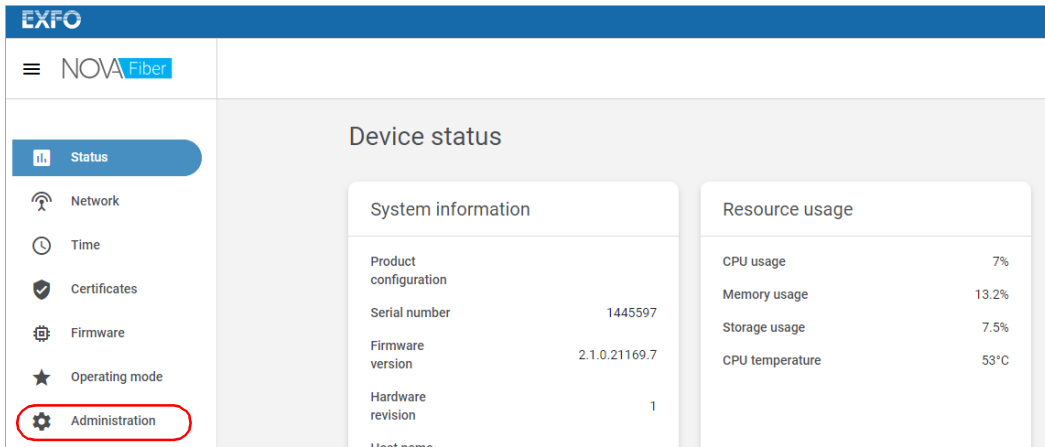

6. Click the **Restart device** or the **Turn off device** button, depending on the operation that you want to perform.

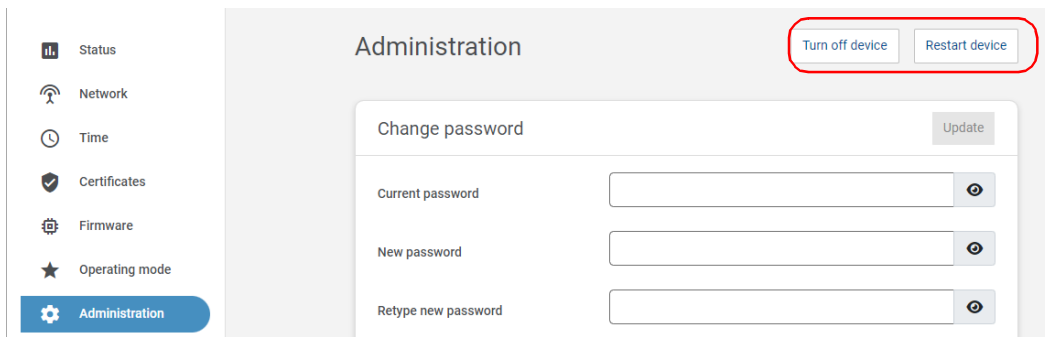

Working With Your Unit for the First Time

By starting to use your unit, you implicitly agree to the EXFO and third-party EULAs related to your unit and instruments.

You will need a computer (laptop) and a network cable to connect to your RTU-2 unit.

By default, the management of your unit is done locally by connecting a laptop to your unit. However, if you prefer to be able to manage your unit remotely (via LAN or WAN) after the first connection, you can enable a feature allowing you to do so. For more information on how to connect remotely to your unit, see *Accessing Your Unit Remotely* on page 69.

The following procedure takes into account that you have already mounted your unit in a rack, grounded it, inserted the test modules, etc. For more information, see the corresponding sections presented earlier in this chapter.

To start working with your unit:

1. If it is not already done, connect your unit to a LAN/WAN network (port on the back panel of the RTU-2 or on the front of the optional access panel, depending on your setup).

Back panel – RTU-2

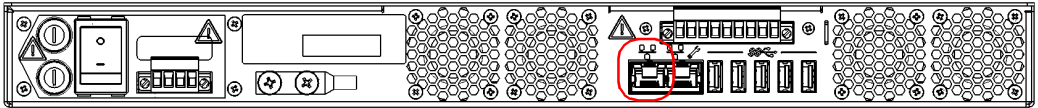

Front view – Optional access panel

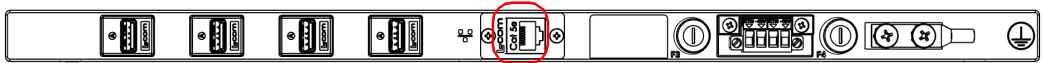

2. If it is not already done, turn on the unit (see *Turning on Your Unit* on page 50).
3. Wait for your unit to be ready (its  (System) LED will be steady green).

Note: *The startup process may take a few minutes to complete.*

8. From the **Status** page, ensure that the test modules have been detected as expected.

	IPv4	IPv6
Addresses	10.28.250.12/24	fe80::203:1ff:fe8:3d74/64
Gateway	10.28.250.1	
Primary DNS	10.28.32.43	
Secondary DNS	10.28.32.9	

Detected test instruments		
Connection type	Model	Serial number
Internal	RTUi-9199-SPLX-4-B-101	1445597
USB	RTUe-9110-DPLX-26-B-101	1061917

9. Configure the network as follows:
- 9a. From the list, select **Network**.

The screenshot shows the EXFO NOVA Fiber web interface. On the left sidebar, the 'Network' menu item is highlighted with a red circle. The main content area displays 'Device status' with two panels: 'System information' and 'Resource usage'.

System information	
Product configuration	

Resource usage	
CPU usage	7%
Memory usage	13.2%

Getting Started with Your Unit

Working With Your Unit for the First Time

- 9b.** Set the IP address and various parameters as needed, and then click **Apply** to confirm.

To access the parameters of
other network adapters

To confirm the changes

EXFO NOVA Fiber RTU-2

Network

Configuration

Adapter LAN/WAN Ethernet

IPv4

Address Obtain address automatically Configure manually

IP address

Subnet mask

Apply



IMPORTANT

To avoid connection problems between your unit and FMS, ensure that the date and time set on your unit correspond to the current date and time.

10. Configure the date and time as follows:

10a. From the list, select **Time**.

10b. By default, the application sets the date and time values to those of the Web browser you are currently using, but you can change them as needed. You can set the date and time manually or use an NTP server. Click **Apply** to confirm.

Note: After a successful connection between FMS and your unit, FMS will provide its own NTP server.

Getting Started with Your Unit

Working With Your Unit for the First Time

11. Configure the list of trusted certificates as follows:

11a. From the list, select **Certificates**.

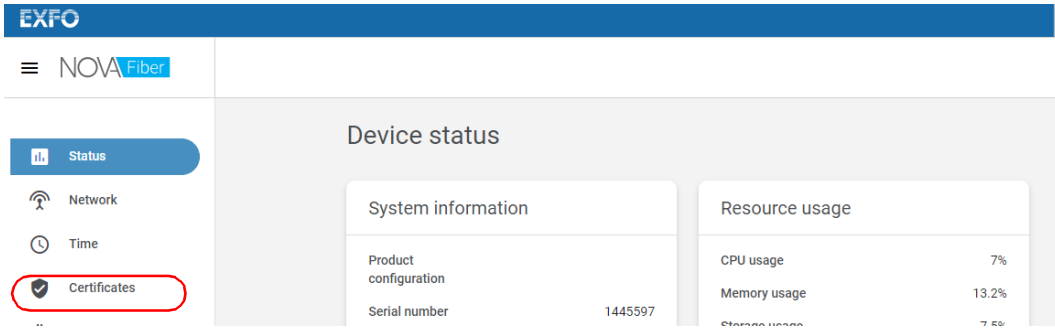

11b. Click **Add** to add a trusted certificate to the list. The certificate file that you provide must be in PEM format.

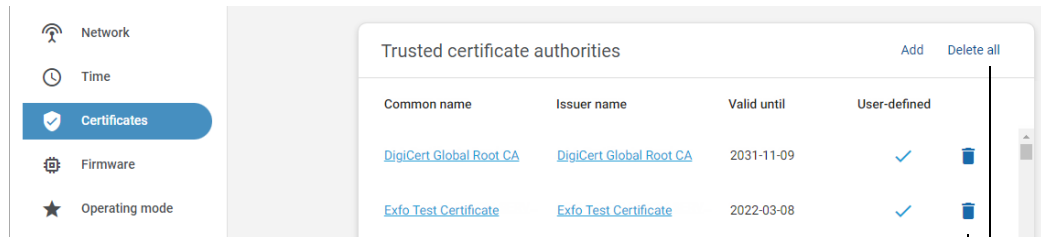

To delete a specific trusted certificate from your unit

To delete all trusted certificates from your unit

11c. Follow the instructions on screen.

12. If desired, ensure that your unit is up to date as follows:

12a. From the list, select **Firmware**.

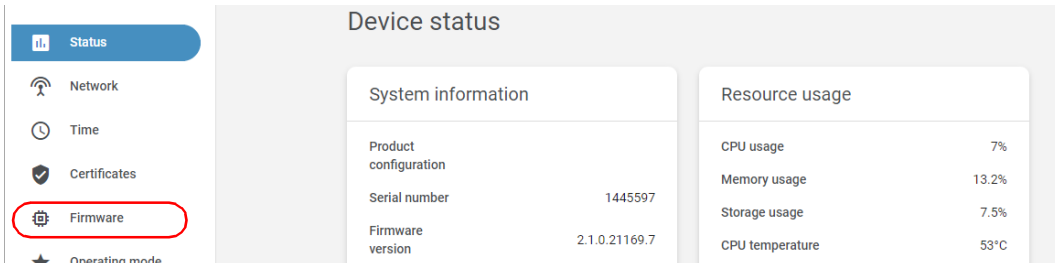

System information		Resource usage	
Product configuration		CPU usage	7%
Serial number	1445597	Memory usage	13.2%
Firmware version	2.1.0.21169.7	Storage usage	7.5%
		CPU temperature	53°C

12b. Click **Check for updates**.

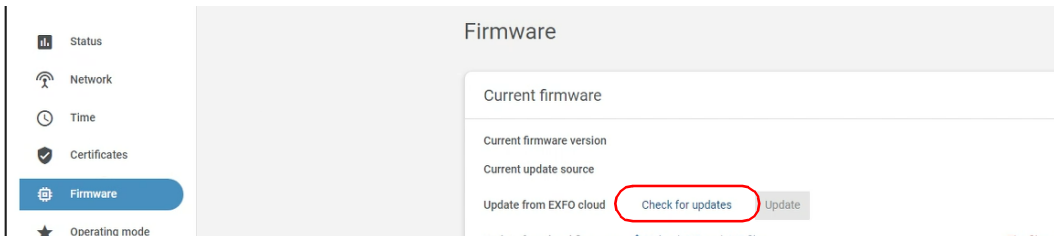

Note: *Your unit must have access to an Internet connection to be able to download updates and install them.*



CAUTION

- For a trouble-free upgrade, ensure that your unit remains on during all the process.
- Turning off your unit (or disconnecting it from its power source) could result in unexpected behavior of the test applications, instability of the system, or even severely damage your unit, depending on the operation underway when the unit is turned off.
Damaged units will need to be sent back to EXFO for repair.

Getting Started with Your Unit

Working With Your Unit for the First Time

12c. If there are updates available, click the **Update** button to start the process. The unit will restart automatically at the end.

12d. Wait for your unit to be ready (its  (System) LED will be steady green), and then connect again to the Web application.

Note: The update operation may take a few minutes to complete.

Note: After a successful connection between FMS and your unit, FMS will provide the updates if your unit is running a compatible version. Refer to the Nova Fiber FMS Readme for the complete compatibility information.

13. Connect your unit to FMS as follows:

13a. From the list, select **Operating mode**.

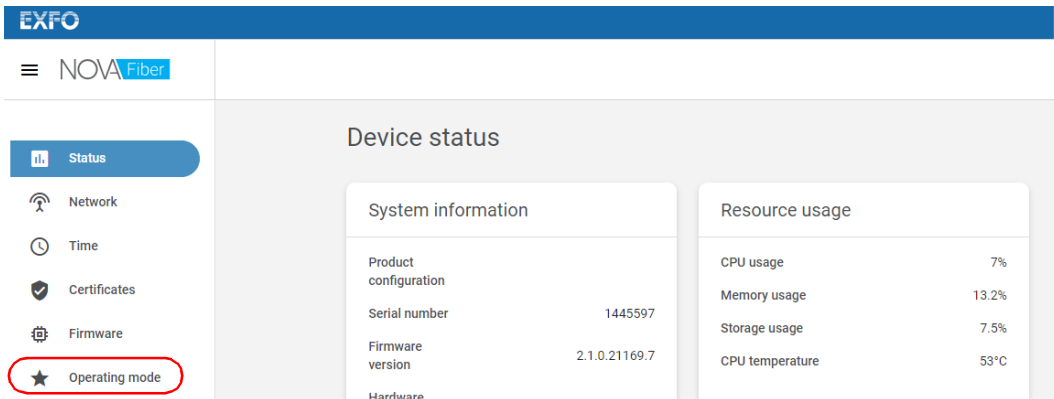

The screenshot shows the EXFO NOVA Fiber web interface. The left sidebar contains a menu with the following items: Status, Network, Time, Certificates, Firmware, and Operating mode. The 'Operating mode' item is highlighted with a red circle. The main content area displays the 'Device status' page, which is divided into two columns: 'System information' and 'Resource usage'.

System information		Resource usage	
Product configuration		CPU usage	7%
Serial number	1445597	Memory usage	13.2%
Firmware version	2.1.0.21169.7	Storage usage	7.5%
Hardware		CPU temperature	53°C

13b. In the Nova Fiber FMS box, enter the name of your FMS server (ex.: *abc.fms.your_company.com*).

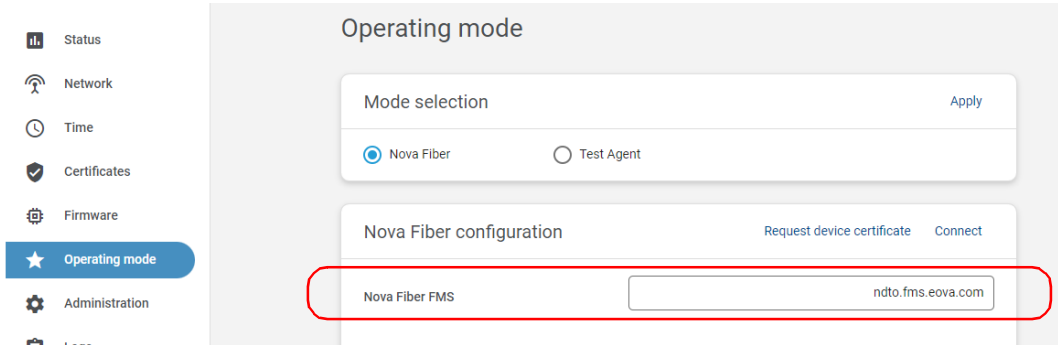

13c. If your system is configured so that FMS requires the authentication of all RTU-2 units, click **Request device certificate**.

OR

If FMS does not require the authentication of the RTU-2 units, go directly to step 13e.

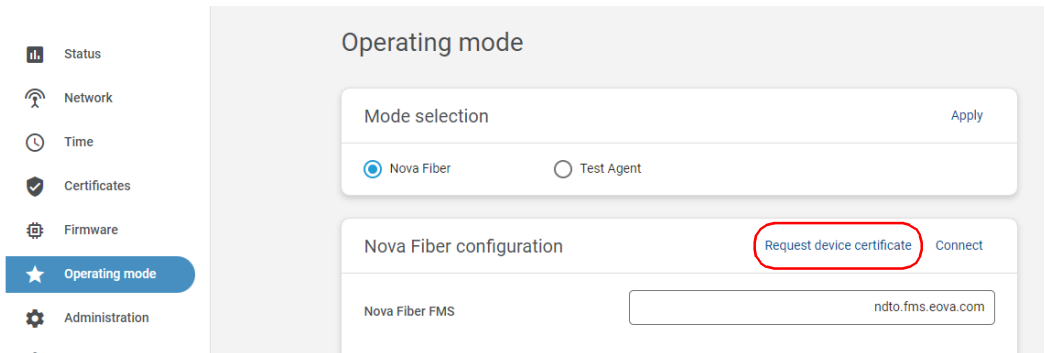

13d. When the application prompts you, enter the username and password for certificate retrieval that was provided by your system administrator. As soon as the application notifies you that the certificate has been updated, you are ready for the connection.

Getting Started with Your Unit

Working With Your Unit for the First Time

13e. Click **Connect** to establish the connection with FMS.

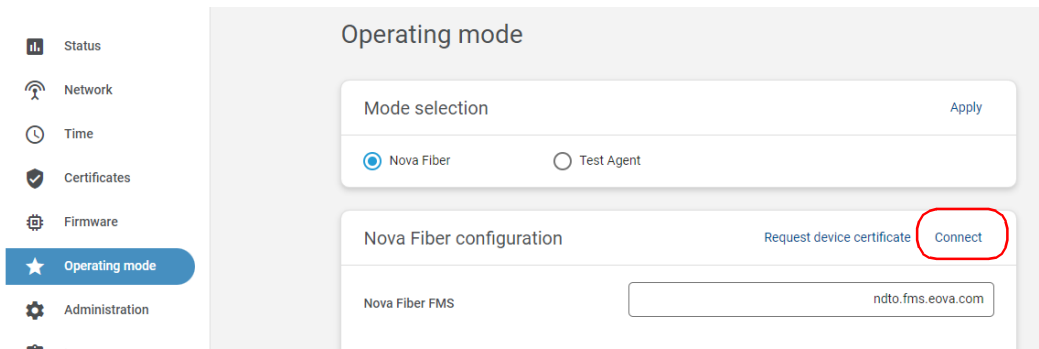

Note: The status of the connection is visible from the **Status** page. The status goes from “Not configured” to “Connecting” to “Established”. If any connection problem occurs, the application will display “Connecting” along with the last error, and the RTU-2 will periodically try to reconnect to the FMS server.

Note: If you need to detach your unit from the link, you can click **Disconnect**. At this point, since there are no monitoring data acquired so far, no data can be lost.

14. If you need to define a login banner, you can do so as follows:

14a. From the list, select **Administration**.

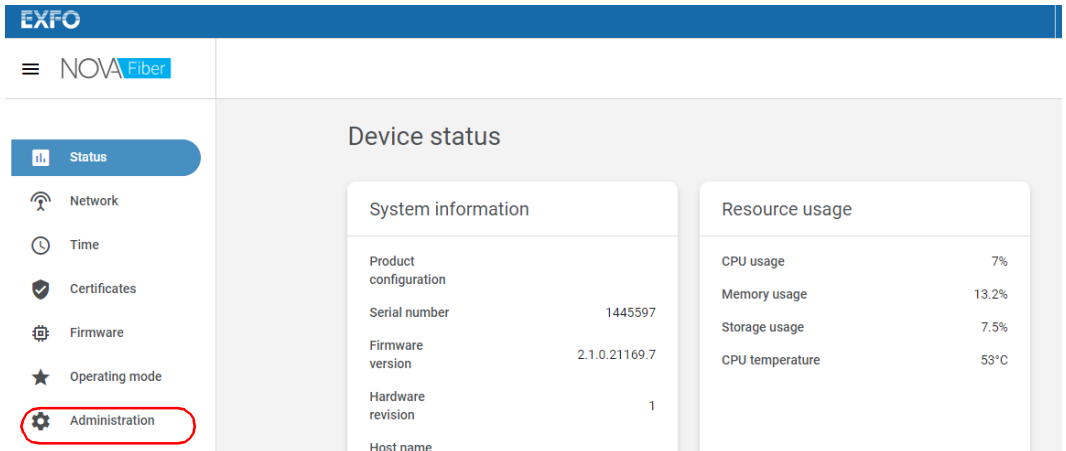

14b. Select the **Enable banner** check box.

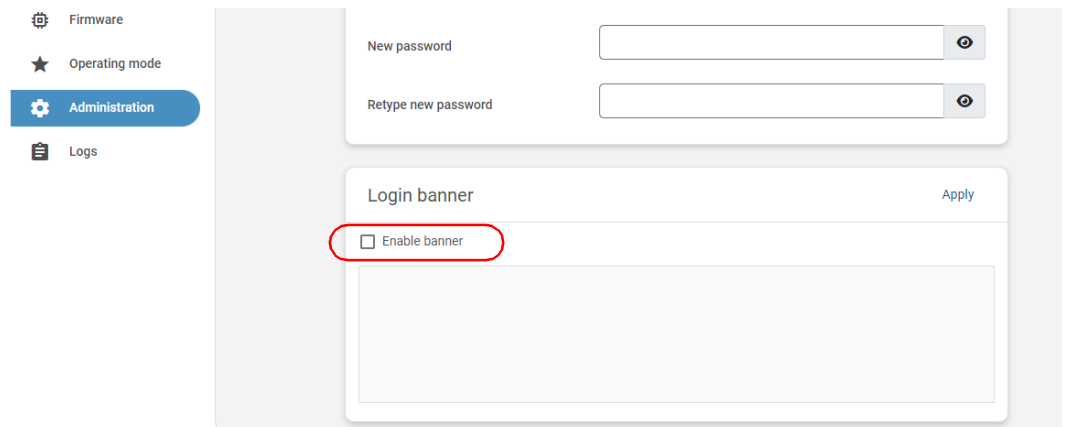

14c. Enter the desired text, and then click **Apply** to confirm.

Getting Started with Your Unit

Working With Your Unit for the First Time

15. If you want to be able to access your unit remotely for management, proceed as follows:

15a. Select the **Enable remote management on LAN/WAN** check box.

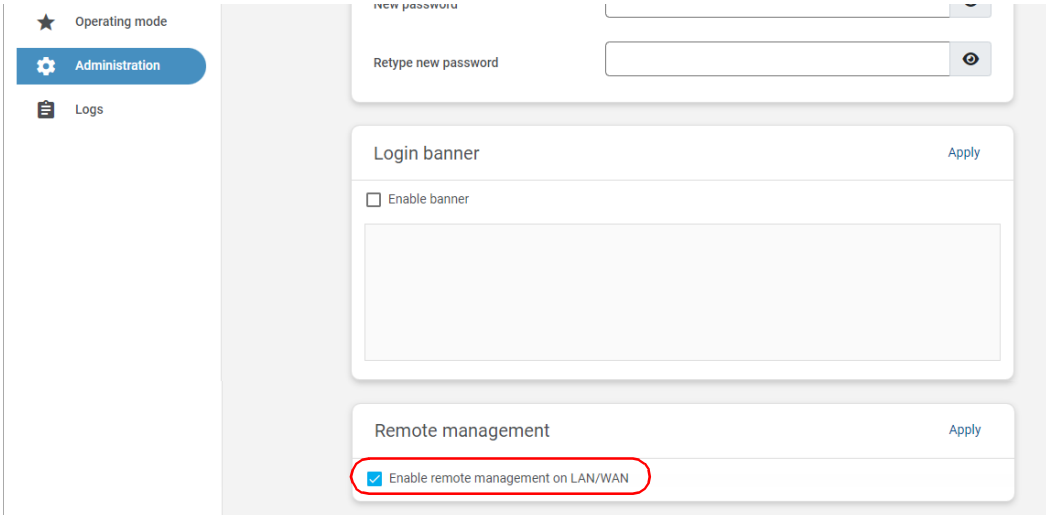

The screenshot displays the configuration interface for an RTU-2 unit. On the left, a navigation menu includes 'Operating mode', 'Administration' (highlighted in blue), and 'Logs'. The main content area is divided into three sections: 'new password' with input fields for 'new password' and 'Retype new password'; 'Login banner' with an 'Apply' button and an unchecked 'Enable banner' checkbox; and 'Remote management' with an 'Apply' button and a checked 'Enable remote management on LAN/WAN' checkbox. A red circle highlights the checked checkbox in the Remote management section.

15b. Click **Apply** to confirm.

Your RTU-2 unit is now configured properly.

4 **Maintenance**

To help ensure long, trouble-free operation:

- Always inspect fiber-optic connectors before using them and clean them if necessary.
- Keep the unit free of dust.
- Clean the unit casing and front panel with a cloth slightly dampened with water.
- Store unit at room temperature in a clean and dry area. Keep the unit out of direct sunlight.
- Avoid high humidity or significant temperature fluctuations.
- Avoid unnecessary shocks and vibrations.
- If any liquids are spilled on or into the unit, turn off the power immediately, disconnect from any external power source and let the unit dry completely.



WARNING

The use of controls, adjustments and procedures, namely for operation and maintenance, other than those specified herein may result in hazardous radiation exposure or impair the protection provided by this unit.

Accessing Your Unit Remotely

By default, the management of your unit is done locally by connecting a laptop to your unit. However, if you prefer to be able to manage your unit remotely (via LAN or WAN) after the first connection, you can enable a feature allowing you to do so.

The following procedure takes into account that you have already configured your unit for remote access. If it is not the case, you will need to connect locally to your unit, and then, from the Nova Fiber application ensure you have enabled the remote access (**Administration** page).

To access your unit remotely:

1. Ensure that the unit is reachable with your computer.
2. On your computer, open a Web browser of your choice.
3. Type *https://<IP_address_of_your_unit>*.

Note: *The unit uses a self-signed certificate, which could cause Web browsers to display a message about security issues.*

Changing the Administrator Password

By default, the administrator user account (user name: localadmin), is protected with the *admin* password.

For security reasons, EXFO recommends that you change the default password for a password of your choice after the first connection, and then periodically, according to your own security policy.

To change the administrator password:

1. Connect to your unit, either locally or remotely. For more information, see *Accessing Your Unit Locally* on page 68 or *Accessing Your Unit Remotely* on page 69.
2. When the application prompts you, enter the connection information.
 - The default user name is: localadmin
 - The default password is: admin



IMPORTANT

The application will lock your account after a certain number of unsuccessful connection attempts. Before entering your connection information again, you will have to wait a few minutes. The waiting time starts increasing after the fifth unsuccessful connection attempt up to a maximum of fifteen minutes.

3. From the list, select **Administration**.

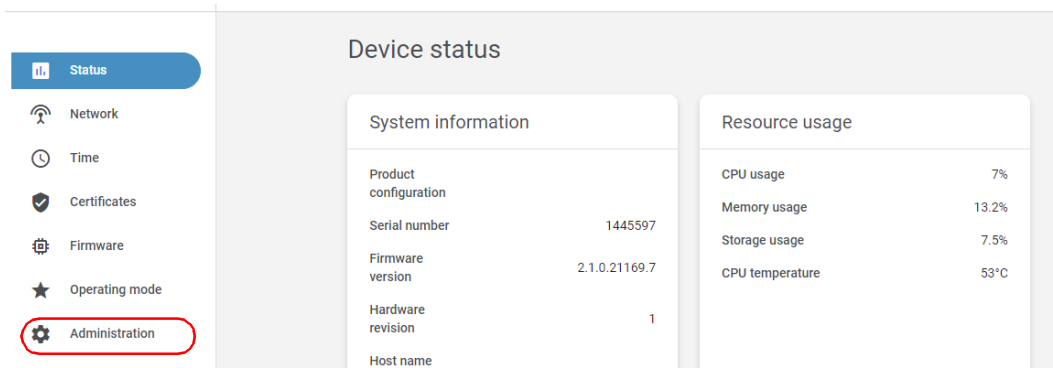

4. Under **Change password**, enter the information.

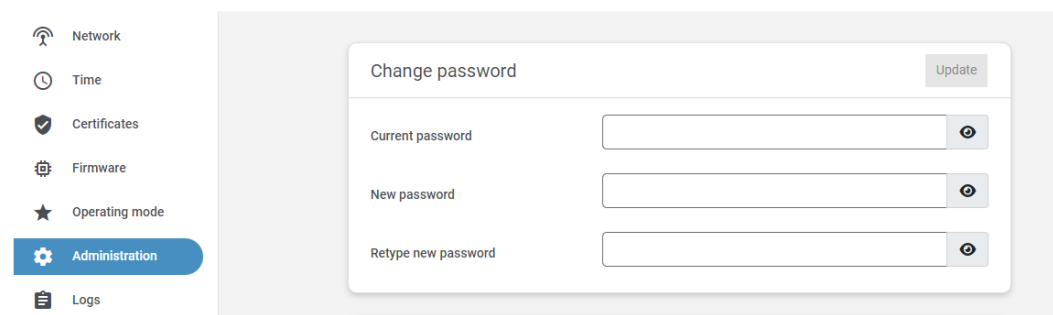

The new password must have a minimum of eight characters and include characters from at least three of the following categories:

- Lowercase letters ('a' - 'z')
- Uppercase letters ('A' - 'Z')
- Numbers (0 - 9)
- Special characters

5. Click **Update** to confirm.

The new password is taken into account immediately.

Upgrading the Firmware

The required firmware has been preinstalled at the factory. However, you may have to upgrade it when new versions become available.

After a successful connection between FMS and your unit, FMS will provide the updates if your unit is running a compatible version. The updates will be performed automatically. Refer to the Nova Fiber FMS Readme for the complete compatibility information and to the FMS user documentation for more information.

If you use your unit as a standalone unit (in Test Agent mode, not connected to FMS), your unit allows you to check for updates, download these updates and install them manually. The information below is useful to upgrade the firmware on standalone units only.

Note: *Your unit must have access to an Internet connection to be able to download updates and install them manually.*



CAUTION

- For a trouble-free upgrade, ensure that your unit remains on during all the process.
- Turning off your unit (or disconnecting it from its power source) could result in unexpected behavior of the test applications, instability of the system, or even severely damage your unit, depending on the operation underway when the unit is turned off.
Damaged units will need to be sent back to EXFO for repair.
- The upgrade could take several minutes to complete. Your unit could restart several times during the operation. You will know that the upgrade is finished when the  (System) LED turns steady green again.

To upgrade the firmware manually:

1. Ensure that your unit has access to the Internet.
2. Connect to your unit, either locally or remotely. For more information, see *Accessing Your Unit Locally* on page 68 or *Accessing Your Unit Remotely* on page 69.
3. When the application prompts you, enter your connection information.
4. From the list, select **Firmware**.

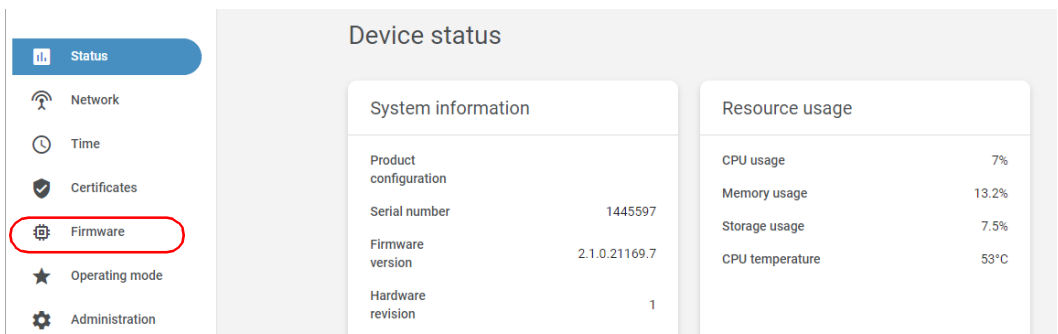

5. Click **Check for updates**.

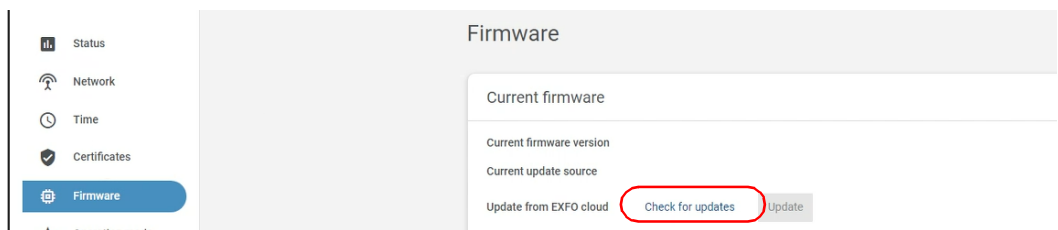

6. If there are updates available, click the **Update** button to start the process. The unit will restart automatically at the end.
7. Wait for your unit to be ready (its  (System) LED will be steady green), and then connect again to the Web application.

Note: *The update operation may take a few minutes to complete.*

Updating Your Unit With Local Firmware

Keeping both FMS (on your server) and the firmware (on your unit) up to date ensures the optimum performance of your system.

However, should a major incompatibility occur between FMS and your unit's firmware, you could upgrade your unit with local firmware to reestablish compatibility between the two.



CAUTION

- For a trouble-free update, ensure that your unit remains on during all the process.
- Turning off your unit (or disconnecting it from its power source) could result in unexpected behavior of the test applications, instability of the system, or even severely damage your unit, depending on the operation underway when the unit is turned off.
Damaged units will need to be sent back to EXFO for repair.
- The update could take several minutes to complete. Your unit will restart at the end of the operation.



IMPORTANT

- If the local firmware update results in a downgrade of versions, some data could be lost in the process. You may want to back up your data before the update.
- Performing a local firmware update **DOES NOT** update the image used to revert the unit to its factory state. For this reason, if you revert your unit to its factory state after performing a local firmware update, the compatibility between FMS and the unit's firmware will be lost again. You will need to perform a new update.

To update your unit with local firmware:

1. Retrieve both the .LIP and .LIS files provided by EXFO to a folder of your choice on your computer (or to a USB key).
2. Connect to your unit, either locally or remotely. For more information, see *Accessing Your Unit Locally* on page 68 or *Accessing Your Unit Remotely* on page 69.
3. When the application prompts you, enter your connection information.
4. From the list, select **Firmware**.

The screenshot shows the EXFO NOVA Fiber web interface. The left sidebar contains a menu with the following items: Status, Network, Time, Certificates, and Firmware. The 'Firmware' item is highlighted with a red circle. The main content area is titled 'Device status' and contains two panels: 'System information' and 'Resource usage'.

System information		Resource usage	
Product configuration		CPU usage	7%
Serial number	1445597	Memory usage	13.2%
Firmware	2.1.0.21169.7	Storage usage	7.5%
		CPU temperature	53.0°C

5. Click **Upload .LIP and .LIS files**.

The screenshot shows the EXFO NOVA Fiber web interface. The left sidebar contains a menu with the following items: Status, Network, Time, Certificates, Firmware, Operating mode, and Administration. The 'Firmware' item is highlighted with a blue bar. The main content area is titled 'Firmware' and contains a 'Current firmware' section with the following options:

- Current firmware version
- Current update source
- Update from EXFO cloud Check for updates
- Update from local firmware **Upload .LIP and .LIS files**

Maintenance

Updating Your Unit With Local Firmware



IMPORTANT

You must select both the .LIP and .LIS files to be able to start the upgrade.

6. Select the .LIP and .LIS files that you want to use. The upgrade starts automatically.

The unit will restart at the end of the operation.

Note: *The update operation may take a few minutes to complete.*

7. Wait for your unit to be ready (its  (System) LED will be steady green), and then connect again to the Web application.

Replacing Fuses

The unit contains two F10A L type fuses (5 mm x 20 mm (0.197 in x 0.787 in), fast-acting, 250 V). The fuse carriers are located at the back of the unit, to the left of the main power switch.

To replace a fuse:

- 1.** Turn off the unit and disconnect it from the power source.
- 2.** With a flat-head screwdriver, slightly push in the cap of the fuse carrier while turning counterclockwise until the fuse carrier is released from the unit.

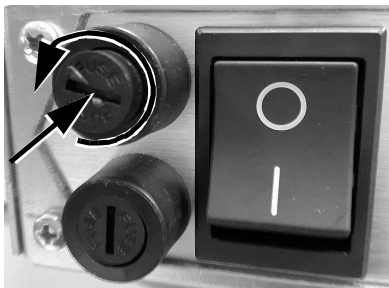

- 3.** Gently pull on the fuse carrier to remove it.
- 4.** Repeat with the second fuse carrier.
- 5.** Check and replace the fuses, if necessary.

Maintenance

Replacing Fuses

6. Insert the new fuse into the fuse carrier.

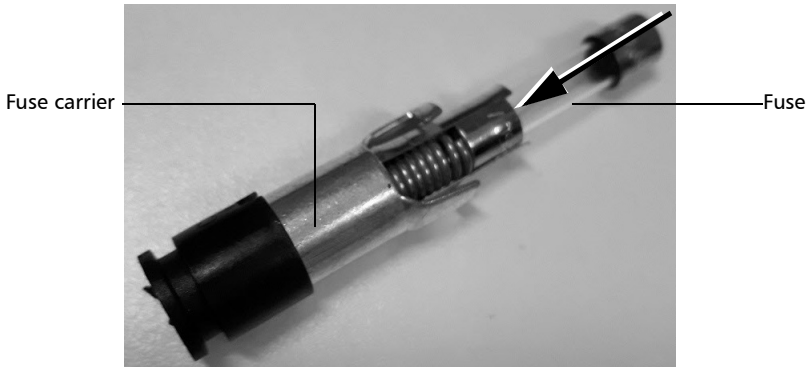

7. Make sure the fuses are placed firmly in the carrier prior to reinsertion.
8. Slide back the first fuse carrier into the unit.
9. With a flat-head screwdriver, slightly push in the cap of the fuse carrier while turning clockwise until the fuse carrier is secured in place.

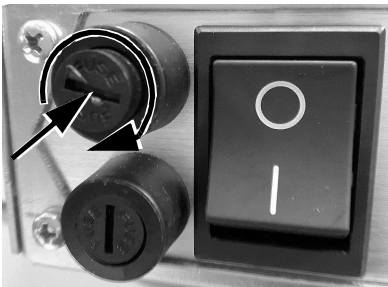

10. Repeat with the second fuse carrier.
11. Connect the unit to the power source and turn on the unit.

Recalibrating Your Modules

When they are used exclusively in a system based on the RTU-2, the FTBx-730C OTDR modules have a recommended calibration interval of three years. This value takes precedence over the recommended interval specified in their respective user guides.

For detailed information about the recalibration of these modules, refer to their user guide.

Recycling and Disposal



This symbol on the product means that you should recycle or dispose of your product (including electric and electronic accessories) properly, in accordance with local regulations. Do not dispose of it in ordinary garbage receptacles.

For complete recycling/disposal information, visit the EXFO Web site at www.exfo.com/recycle.

5 Troubleshooting

Solving Common Problems

Before calling EXFO's technical support, you may want to consider the following solutions to problems that could occur.

Problem	Possible Cause	Solution
<p>My unit does not start. Its power LED (🔌) remains off when I press the on/off button.</p>	<p>There is a problem related to electrical power.</p>	<ul style="list-style-type: none">➤ If your unit is connected to DC power, make sure that the disconnect device is turned on. If your unit is connected to AC power, make sure that the external power supply is connected at both ends, and that the disconnect device is turned on.➤ Ensure that the main power switch, located at the back of your unit, is in the on position.➤ Check the fuses (see <i>Replacing Fuses</i> on page 77).➤ If the unit is connected to DC power, ensure that the wires are connected properly, respecting polarity (see <i>Connecting Your Unit to a Power Source</i> on page 42).

Troubleshooting

Solving Common Problems

Problem	Possible Cause	Solution
The RTUe-9110/RTUe-9120 external switch that I have just connected is not working.	The switch has not been detected.	Disconnect, then reconnect the switch. Ensure that the RTU-2 unit is on and that its System LED () is green and not blinking.
The unit does not recognize a test module.	Defective module.	If the unit recognizes other modules, the faulty module could be defective. Return it to EXFO for repairs.
	Module is not supported on your unit.	Refer to the unit's technical specifications for the complete list of supported modules.
I cannot sign in to my account with my user name and password.	The application locked your account after five or more unsuccessful connection attempts.	Wait a few minutes before attempting a new connection. After eight unsuccessful attempts, you will have to wait 15 minutes before trying again.
	You forgot or lost your password.	Create a new password with FMS. For more information about FMS, refer to its user documentation.

Restoring Your Unit to Normal Operation

If you ever encounter major problems with your unit (for example, the unit does not behave the way it used to), you can revert it to its initial state (as it was at time of purchase).

When you reset your unit to its factory settings:

- All data files will be lost once the operation is complete.
- If you have installed products and updates since you purchased your unit, you will have to reinstall them.



IMPORTANT

Resetting your unit to its factory settings will disable the remote management if it was enabled. This means that, once the operation is complete, you will no longer be able to connect remotely to your unit.



CAUTION

DO NOT TURN OFF your unit while the recovery operation is underway. Doing so may severely damage your unit. Damaged units will need to be sent back to EXFO for repair.

You can perform this operation from the Nova Fiber application or manually, especially if you cannot access the Nova Fiber application.

To restore your unit to factory state with the Nova Fiber application:

1. Connect to your unit, either locally or remotely. For more information, see *Accessing Your Unit Locally* on page 68 or *Accessing Your Unit Remotely* on page 69.
2. When the application prompts you, enter your connection information.

Troubleshooting

Restoring Your Unit to Normal Operation

3. From the list, select **Administration**.

The screenshot shows the 'Device status' page. On the left sidebar, the 'Administration' option is highlighted with a red circle. The main content area is titled 'Device status' and contains two panels: 'System information' and 'Resource usage'.

System information	
Product configuration	
Serial number	1445597
Firmware version	2.1.0.21169.7
Hardware revision	1
Host name	

Resource usage	
CPU usage	7%
Memory usage	13.2%
Storage usage	7.5%
CPU temperature	53°C

4. Click **Restore device to factory state**.

The screenshot shows the 'Administration' page. The left sidebar has 'Administration' highlighted. The main content area includes:

- Retype new password**: A password input field with a visibility toggle.
- Login banner**: An 'Apply' button and a checkbox for 'Enable banner'.
- Remote management**: An 'Apply' button and a checked checkbox for 'Enable remote management on LAN/WAN'.
- Reset**: A button labeled 'Restore device to factory state' is highlighted with a red circle.

5. Follow the on-screen instructions.

The restoring process is now underway and the  (System) LED will keep blinking rapidly. Your unit will restart automatically.

Once your unit has restarted, its  (System) LED will blink slowly during the whole initialization. You will know that the operation is complete when the LED becomes steady green.

Note: *The restoring process may take a few minutes to complete.*

6. Configure your unit as you did when you first received it. However, use the following credentials to establish a connection:
 - User name: admin
 - Password: admin

Note: *Depending on when your unit was manufactured, the default user name could be admin or localadmin.*

For more information, see *Working With Your Unit for the First Time* on page 54.

Troubleshooting

Restoring Your Unit to Normal Operation

To restore your unit to its factory state without the Nova Fiber application:

1. Turn off you unit.
2. Connect a keyboard to one of your unit's USB ports.
3. Turn on your unit and then start pressing and holding down the R key until the  (System) LED starts blinking.

Note: *You could also launch the restoring process by pressing (and releasing) the Down arrow key repeatedly during about ten seconds, and then pressing Enter.*

The  (System) LED will blink during the whole restoring operation. Your unit will restart automatically.

You will know that the operation is complete when the  (System) LED becomes steady green.

Note: *The restoring process may take a few minutes to complete.*

4. Configure your unit as you did when you first received it (see *Working With Your Unit for the First Time* on page 54).

Accessing the User Documentation

You can access the user documentation in PDF format at all times from your unit.

Note: *The user guides of all products are also available from the My EXFO section of the EXFO Web site (www.exfo.com) for download in PDF format.*

To view the user documentation:

From the title bar of the Nova Fiber application, click .

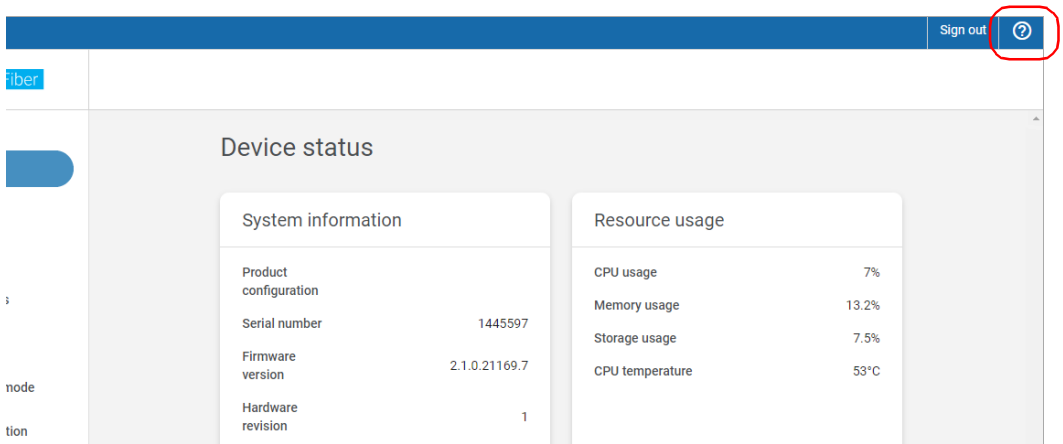

Retrieving Logs

There are two types of logs that you can retrieve from the Nova Fiber Web application:

- The audit log that lists events and changes that occurred on the RTU-2 unit.
- The system log that provides special information that you can send to the technical support team at EXFO for further analysis.

To retrieve logs:

1. Connect to your unit, either locally or remotely. For more information, see *Accessing Your Unit Locally* on page 68 or *Accessing Your Unit Remotely* on page 69.
2. From the Nova Fiber Web application, go to the **Logs** page.

The screenshot shows the EXFO NOVA Fiber web application interface. The top navigation bar is blue with the EXFO logo. Below it, the 'NOVA Fiber' title is displayed. A left sidebar contains a menu with the following items: Status (highlighted in blue), Network, Time, Certificates, Firmware, Operating mode, Administration, and Logs (highlighted with a red circle). The main content area is titled 'Device status' and contains two panels: 'System information' and 'Resource usage'.

System information	
Product configuration	
Serial number	1445597
Firmware version	2.1.0.21169.7
Hardware revision	1
Host name	
Bluetooth	Disabled

Resource usage	
CPU usage	7%
Memory usage	13.2%
Storage usage	7.5%
CPU temperature	53°C

3. Go to the section corresponding to the type of log that you want to retrieve, and then click the corresponding **Download** link.

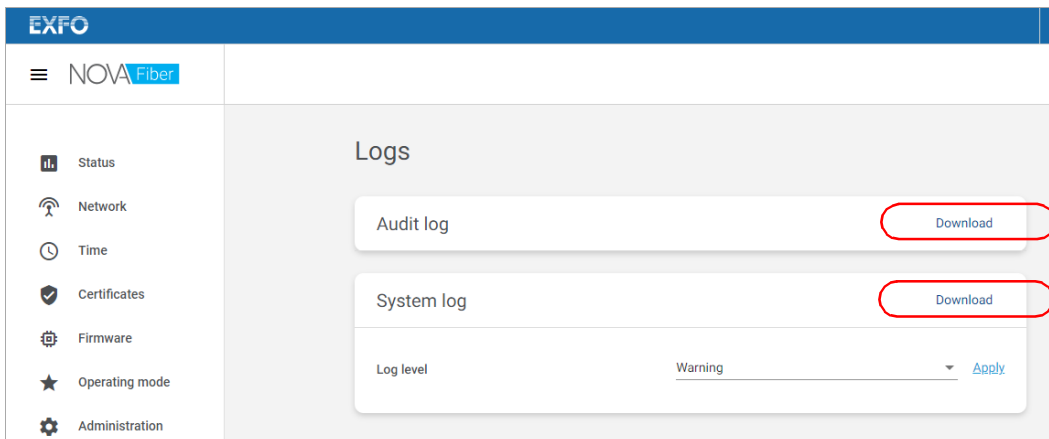

Note: *By default, the logging level of the system log is set to Warning. If necessary, the technical support team will ask you to change the level to another value for subsequent actions. The Debug level should be used temporarily as it can slow down the system. EXFO recommends to set the level back to Warning once the debug operation is complete.*

Note: *The time necessary to retrieve a log will vary with its size.*

Troubleshooting

Contacting the Technical Support Group

Contacting the Technical Support Group

To obtain after-sales service or technical support for this product, contact EXFO at one of the following numbers. The Technical Support Group is available to take your calls from Monday to Friday, 8:00 a.m. to 7:00 p.m. (Eastern Time in North America).

Technical Support Group

400 Godin Avenue
Quebec (Quebec) G1M 2K2
CANADA

1 866 683-0155 (USA and Canada)
Tel.: 1 418 683-5498
Fax: 1 418 683-9224
support.serviceassurance@exfo.com

For detailed information about technical support, and for a list of other worldwide locations, visit the EXFO Web site at www.exfo.com.

If you have comments or suggestions about this user documentation, you can send them to customer.feedback.manual@exfo.com.

To accelerate the process, please have information such as the name and the serial number (see the product identification label), as well as a description of your problem, close at hand.

Transportation

Maintain a temperature range within specifications when transporting the unit. Transportation damage can occur from improper handling. The following steps are recommended to minimize the possibility of damage:

- Pack the unit in its original packing material when shipping.
- Avoid high humidity or large temperature fluctuations.
- Keep the unit out of direct sunlight.
- Avoid unnecessary shocks and vibrations.

6 **Warranty**

General Information

EXFO Inc. (EXFO) warrants this equipment against defects in material and workmanship for a period of two years from the date of original shipment. EXFO also warrants that this equipment will meet applicable specifications under normal use.

During the warranty period, EXFO will, at its discretion, repair, replace, or issue credit for any defective product, as well as verify and adjust the product free of charge should the equipment need to be repaired or if the original calibration is erroneous. If the equipment is sent back for verification of calibration during the warranty period and found to meet all published specifications, EXFO will charge standard calibration fees.



IMPORTANT

The warranty can become null and void if:

- **unit has been tampered with, repaired, or worked upon by unauthorized individuals or non-EXFO personnel.**
- **warranty sticker has been removed.**
- **case screws, other than those specified in this guide, have been removed.**
- **case has been opened, other than as explained in this guide.**
- **unit serial number has been altered, erased, or removed.**
- **unit has been misused, neglected, or damaged by accident.**

THIS WARRANTY IS IN LIEU OF ALL OTHER WARRANTIES EXPRESSED, IMPLIED, OR STATUTORY, INCLUDING, BUT NOT LIMITED TO, THE IMPLIED WARRANTIES OF MERCHANTABILITY AND FITNESS FOR A PARTICULAR PURPOSE. IN NO EVENT SHALL EXFO BE LIABLE FOR SPECIAL, INCIDENTAL, OR CONSEQUENTIAL DAMAGES.

Warranty

Gray Market and Gray Market Products

Gray Market and Gray Market Products

Gray market is a market where products are traded through distribution channels that are legal but remain unofficial, unauthorized, or unintended by the original manufacturer. Intermediaries using such channels to distribute products are considered to be part of the gray market (hereafter unauthorized intermediary).

EXFO considers that a product originates from the gray market (hereafter gray market product) in the following situations:

- A product is sold by an unauthorized intermediary.
- A product is designed and destined for a particular market and sold on a second market.
- A product is resold, despite being reported lost or stolen.

When products are purchased on the gray market, rather than through an authorized EXFO distribution channel, EXFO is unable to guarantee the source and quality of those products nor the local safety regulations and certifications (CE, UL, etc.).

EXFO will not honor warranty, install, maintain, repair, calibrate, provide technical support nor make any support contracts available for gray market products.

For complete information, refer to EXFO's policy regarding gray market products at

www.exfo.com/en/how-to-buy/sales-terms-conditions/gray-market/

Liability

EXFO shall not be liable for damages resulting from the use of the product, nor shall be responsible for any failure in the performance of other items to which the product is connected or the operation of any system of which the product may be a part.

EXFO shall not be liable for damages resulting from improper usage or unauthorized modification of the product, its accompanying accessories and software.

Exclusions

EXFO reserves the right to make changes in the design or construction of any of its products at any time without incurring obligation to make any changes whatsoever on units purchased. Accessories, including but not limited to fuses, pilot lamps, batteries and universal interfaces (EUI) used with EXFO products are not covered by this warranty.

This warranty excludes failure resulting from: improper use or installation, normal wear and tear, accident, abuse, neglect, fire, water, lightning or other acts of nature, causes external to the product or other factors beyond the control of EXFO.



IMPORTANT

In the case of products equipped with optical connectors, EXFO will charge a fee for replacing connectors that were damaged due to misuse or bad cleaning.

Certification

EXFO certifies that this equipment met its published specifications at the time of shipment from the factory.

Service and Repairs

EXFO commits to providing product service and repair for five years following the date of purchase.

To send any equipment for service or repair:

1. Call one of EXFO's authorized service centers (see *EXFO Service Centers Worldwide* on page 95). Support personnel will determine if the equipment requires service, repair, or calibration.
2. If equipment must be returned to EXFO or an authorized service center, support personnel will issue a Return Merchandise Authorization (RMA) number and provide an address for return.
3. If possible, back up your data before sending the unit for repair.
4. Pack the equipment in its original shipping material. Be sure to include a statement or report fully detailing the defect and the conditions under which it was observed.
5. Return the equipment, prepaid, to the address given to you by support personnel. Be sure to write the RMA number on the shipping slip. *EXFO will refuse and return any package that does not bear an RMA number.*

Note: *A test setup fee will apply to any returned unit that, after test, is found to meet the applicable specifications.*

After repair, the equipment will be returned with a repair report. If the equipment is not under warranty, you will be invoiced for the cost appearing on this report. EXFO will pay return-to-customer shipping costs for equipment under warranty. Shipping insurance is at your expense.

Routine recalibration is not included in any of the warranty plans. Since calibrations/verifications are not covered by the basic or extended warranties, you may elect to purchase FlexCare Calibration/Verification Packages for a definite period of time. Contact an authorized service center (see *EXFO Service Centers Worldwide* on page 95).

EXFO Service Centers Worldwide

If your product requires servicing, contact your nearest authorized service center.

EXFO Headquarters Service Center

400 Godin Avenue
Quebec (Quebec) G1M 2K2
CANADA

1 866 683-0155 (USA and Canada)
Tel.: 1 418 683-5498
Fax: 1 418 683-9224
support@exfo.com

EXFO Europe Service Center

Winchester House, School Lane
Chandlers Ford, Hampshire S053 4DG
ENGLAND

Tel.: +44 2380 246800
Fax: +44 2380 246801
support.europe@exfo.com

EXFO Telecom Equipment (Shenzhen) Ltd.

3rd Floor, Building C,
FuNing Hi-Tech Industrial Park, No. 71-3,
Xintian Avenue,
Fuhai, Bao'An District,
Shenzhen, China, 518103

Tel: +86 (755) 2955 3100
Fax: +86 (755) 2955 3101
support.asia@exfo.com

To view EXFO's network of partner-operated Certified Service Centers nearest you, please consult EXFO's corporate website for the complete list of service partners:

<http://www.exfo.com/support/services/instrument-services/exfo-service-centers>.

Index

	A	
AC		
adapter		13
connection		3, 43, 47
power		31, 42, 47
requirements		15
accessing online help		87
adding external switch		40
after-sales service		90
amber LED		4
applications, installing		72
automatic fan speed		16
	B	
black LED		4
blinking LED		4
boot, first		54
	C	
cabinet installation		27
capacitors		14
cascading external switches		41
caution		
of personal hazard		7
of product hazard		7
changing administrator password		70
cleaning		
front panel		67
colors, LEDs		4
configuring unit		54
connecting		
external switch to unit		40
multiple external switches		41
to Nova Fiber		70
unit to AC power		42, 47
unit to DC power		42, 43
conventions, safety		7
covers, unit		14
current, electrical		15
customer service		94
	D	
DC power		31, 42, 43
documentation		87
dry contact relays		33
	E	
equipment returns		94
Ethernet port location		2, 3, 4
ETSI racks		27
external		
power supply		13
switch, connecting to unit		40
	F	
factory settings, resetting unit to		83
fan speed		16
firmware update		72
first startup		54
flashing LED		4
front panel, cleaning		67
fuse		
replacement		14, 77
type		14, 77
	G	
green LED		4
grounding unit		31
	H	
hazard, laser radiation		12
help, online		87

Index

I

identification label	90
indoor use	14
input current	15
inserting module	37
installing	
software	72
unit in rack	27, 28
unit, requirements	14

L

label, identification	90
laser safety information	12
LED	
indicators	4
power	4
system	5
lug, grounding	31

M

main power switch	3, 43, 47
maintenance	
front panel	67
general information	67
port	3, 4
manuals	87
maximum input current	15
module	
insertion	37
removal	37
mounting brackets	27

N

normal operation, returning to	83
--------------------------------------	----

O

off LED	4
online help	87
orange LED	4

P

password, changing	70
pinout of the relays	33
plugging unit	42
ports	
Ethernet	2, 3, 4
USB	2, 3, 4
power	
connecting	42
LED	4
relay	33
sources	15
supply	13
switch, main	3, 43, 47
product	
identification label	90
specifications	6

R

rack	
dimensions	27
installing units in	28
radiation hazard, laser	12
red LED	4
regulatory information	v, viii
relays, dry contact	33
removing module	37
repairing unit	14
replacing fuses	77
requirements for installation	17
return merchandise authorization (RMA)	94
reverting unit to factory settings	83
RJ-45 port	3, 4
RTU-2, installing	28

S

safety	
caution	7
conventions	7
grounding unit	31

information 12
warning 7
service and repairs 94
service centers 95
shipping to EXFO 94
shutdown mode 51
software, installing and upgrading 72
specifications, product 6
static IP port 3
storage requirements 67
symbols, safety 7
system
 LED 5
 relay 33

T

technical specifications 6
technical support 90
temperature for storage 67
transportation requirements 67, 90
turning unit on/off 50, 51
type of fuses 14

U

unit
 connecting to AC power 47
 connecting to DC power 43
 covers 14
 first configuration 54
 grounding 31
 installing 14, 17, 28
 repairing 14
 ventilation 14
updating applications 72
upgrade, firmware 72
USB ports 2, 3, 4
user guides 87

V

ventilation 14

W

warranty
 certification 93
 exclusions 93
 general 91
 liability 93
 null and void 91
wizard, configuration 54

Y

yellow LED 4

CHINESE REGULATION ON RESTRICTION OF HAZARDOUS SUBSTANCES (RoHS)

中国关于有害物质限制的规定

NAMES AND CONTENTS OF THE TOXIC OR HAZARDOUS SUBSTANCES OR ELEMENTS
CONTAINED IN THIS EXFO PRODUCT

包含在本 EXFO 产品中的有毒有害物质或元素的名称及含量

Part Name 部件名称	Lead 铅 (Pb)	Mercury 汞 (Hg)	Cadmium 镉 (Cd)	Hexavalent Chromium 六价铬 (Cr(VI))	Polybrominated biphenyls 多溴联苯 (PBB)	Polybrominated diphenyl ethers 多溴二苯醚 (PBDE)
Enclosure 外壳	O	O	O	O	O	O
Electronic and electrical sub-assembly 电子和电气组件	X	O	X	O	X	X
Optical sub-assembly ^a 光学组件 ^a	X	O	O	O	O	O
Mechanical sub-assembly ^a 机械组件 ^a	O	O	O	O	O	O

Note:

注:

This table is prepared in accordance with the provisions of SJ/T 11364.

本表依据 SJ/T 11364 的规定编制。

O: Indicates that said hazardous substance contained in all of the homogeneous materials for this part is below the limit requirement of GB/T 26572.

O: 表示该有害物质在该部件所有均质材料中的含量均在 GB/T 26572 标准规定的限量要求以下。

X: indicates that said hazardous substance contained in at least one of the homogeneous materials used for this part is above the limit requirement of GB/T 26572. Due to the limitations in current technologies, parts with the "X" mark cannot eliminate hazardous substances.



X: 表示该有害物质至少在该部件的某一均质材料中的含量超出 GB/T 26572 标准规定的限量要求。

标记 "X" 的部件, 皆因全球技术发展水平限制而无法实现有害物质的替代。

a. If applicable.

如果适用。

MARKING REQUIREMENTS
标注要求

Product 产品	Environmental protection use period (years) 环境保护使用期限 (年)	Logo 标志
This EXFO product 本 EXFO 产品	10	
Battery ^a 电池	5	

a. If applicable.
如果适用。

P/N: 1086480

www.EXFO.com · info@EXFO.com

CORPORATE HEADQUARTERS 400 Godin Avenue

Quebec (Quebec) G1M 2K2 CANADA
Tel.: 1 418 683-0211 · Fax: 1 418 683-2170

TOLL-FREE (USA and Canada)

1 800 663-3936

© 2023 EXFO Inc. All rights reserved.
Printed in Canada (2023-05)

