

FTB-5800

Chromatic Dispersion Analyzer for FTB-500



Copyright © 2002–2009 EXFO Electro-Optical Engineering Inc. All rights reserved. No part of this publication may be reproduced, stored in a retrieval system or transmitted in any form, be it electronically, mechanically, or by any other means such as photocopying, recording or otherwise, without the prior written permission of EXFO Electro-Optical Engineering Inc. (EXFO).

Information provided by EXFO is believed to be accurate and reliable. However, no responsibility is assumed by EXFO for its use nor for any infringements of patents or other rights of third parties that may result from its use. No license is granted by implication or otherwise under any patent rights of EXFO.

EXFO's Commerce And Government Entities (CAGE) code under the North Atlantic Treaty Organization (NATO) is 0L8C3.

The information contained in this publication is subject to change without notice.

Trademarks

EXFO's trademarks have been identified as such. However, the presence or absence of such identification does not affect the legal status of any trademark.

Units of Measurement

Units of measurement in this publication conform to SI standards and practices.

Patents

The Chromatic Dispersion Analyzer is protected by US patent 6,429,929 and foreign equivalents; EXFO's Universal Interface is protected by US patent 6,612,750.

Version number 3.0.0

Contents

Certification Information	v
1 Introducing the FTB-5800 Chromatic Dispersion Analyzer	1
Main Features	1
Basic Theory	3
Typical Applications	3
Conventions	4
2 Getting Started with Your Chromatic Dispersion Analyzer	5
Inserting and Removing Test Modules	5
Starting the Chromatic Dispersion Analyzer Application	9
Exiting the Application	12
3 Setting Up Your Chromatic Dispersion Analyzer	13
Setting the Wavelength Range	13
Setting the Wavelength Step	14
Setting the Averaging Time	16
Specifying the Fiber Under Test	17
Defining the Automatic Fiber Name Format	20
4 Operating Your Chromatic Dispersion Analyzer	23
Installing the EXFO Universal Interface (EUI)	23
Cleaning and Connecting Optical Fibers	24
Selecting the Source Type	26
Verifying the Intensity of the Source	27
Performing Reference Measurements	28
Applying a Chromatic Dispersion Reference	33
Creating a File	34
Measuring Chromatic Dispersion	35
Saving Your Results	38
5 Managing Results	41
Recalling a Saved File	42
Analyzing Results from the Results Graph	43
Analyzing Results from the Results Table	52
Keeping Track of Acquisitions	54
Establishing Thresholds	56
Documenting Results	59
Exporting Results and Graphs to Clipboard	61
Printing Results	62

Contents

6	Exporting CD Analyzer Files with the File Export Tool	65
	Starting and Exiting the File Export Tool	65
	Setting Export Parameters	67
	Exporting Chromatic Dispersion Files	69
7	Maintenance	71
	Cleaning EUI Connectors	72
	Cleaning Detector Ports	74
	Recalibrating the Unit	75
	Recycling and Disposal (Applies to European Union Only)	76
8	Troubleshooting	77
	Solving Common Problems	77
	Viewing Online Documentation	79
	Contacting the Technical Support Group	80
	Transportation	81
9	Warranty	83
	General Information	83
	Liability	84
	Exclusions	85
	Certification	85
	Service and Repairs	86
	EXFO Service Centers Worldwide	87
A	Technical Specifications	89
B	Measuring Chromatic Dispersion: Theory	91
	Method Behind the Chromatic Dispersion Analyzer	91
	Using Data Fits to Obtain Dispersion	92
	Helping You Manage Chromatic Dispersion	94
	Index	95

Certification Information

F.C.C. Information

Electronic test equipment is exempt from Part 15 compliance (FCC) in the United States. However, compliance verification tests are systematically performed on most EXFO equipment.

CE Information

Electronic test equipment is subject to the EMC Directive in the European Union. The EN61326 standard prescribes both emission and immunity requirements for laboratory, measurement, and control equipment. This unit has undergone extensive testing according to the European Union Directive and Standards.

EXFO DECLARATION OF CONFORMITY

Application of Council Directive(s):	2006/95/EC - The Low Voltage Directive 2004/108/EC - The EMC Directive And their amendments
Manufacturer's Name:	EXFO Electro-Optical Engineering Inc.
Manufacturer's Address:	400 Godin Avenue Quebec, Quebec Canada, G1M 2K2 (418) 683-0211
Equipment Type/Environment:	Test & Measurement / Industrial
Trade Name/Model No.:	FTB-5800 Chromatic Dispersion Analyzer

Standard(s) to which Conformity is Declared:

EN 61010-1:2001	Safety Requirements for Electrical Equipment for Measurement, Control, and Laboratory Use, Part 1: General Requirements.
EN 61326-1:2006	Electrical Equipment for Measurement, Control and Laboratory Use - EMC Requirements – Part 1: General requirements
EN 60825-1:1994 +A2:2001 +A1:2002	Safety of laser products – Part 1: Equipment classification, requirements, and user's guide
EN 55022: 1998 +A2: 2003	Information technology equipment - Radio disturbance characteristics - Limits and methods of measurement

I, the undersigned, hereby declare that the equipment specified above conforms to the above Directive and Standards.

Manufacturer

Signature:



Full Name: Stephen Bull, E, Eng
Position: Vice-President Research and Development
Address: 400 Godin Avenue, Quebec (Quebec),
Canada, G1M 2K2
Date: January 09, 2009

1 Introducing the FTB-5800 Chromatic Dispersion Analyzer

In today's advanced optical network, chromatic dispersion management has become an important issue. Present-day networks must deal with high data rates, high channel counts and long distances between optical-electrical-optical regenerators.

Main Features

The FTB-5800 Chromatic Dispersion Analyzer is a reliable solution to chromatic dispersion management. It uses the phase-shift measurement method to measure phase variations at fixed frequencies and combines them relative group delays.

Fitting equations are then applied to the computed data to calculate chromatic dispersion. This method allows for more accurate and precise results in the C and L bands.

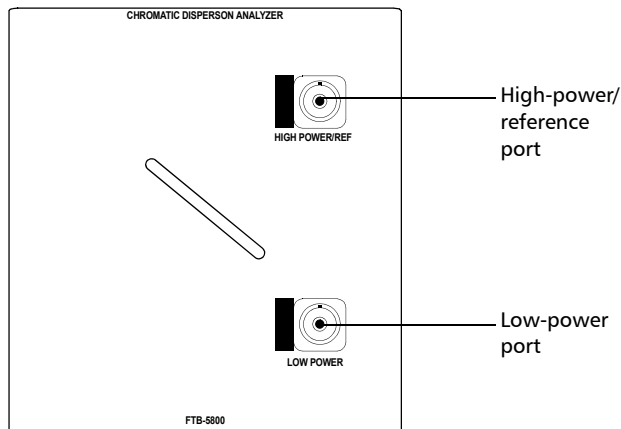

Introducing the FTB-5800 Chromatic Dispersion Analyzer

Main Features

The architecture of the FTB-5800 Chromatic Dispersion Analyzer places the wavelength selector in the receiver, which avoids the necessity for any communication between the receiver and the source. This allows you to take measurements even though the source is kilometers away, without interfering with the accuracy of results.

The FTB-5800 Chromatic Dispersion Analyzer is offered as a compact, portable and field-ready module used in the FTB-500 Universal Test Platform and combined with the FLS-5800 for optimal test results. The FTB-5800 Chromatic Dispersion Analyzer comes with user-friendly software, which allows you to perform your acquisition, and then view, analyze and save your results easily.

Basic Theory

Chromatic dispersion is the natural broadening of light pulses as they travel through optical fiber. The propagation characteristics of each wavelength depend on the refractive index of the medium and on the non-linearity of the propagation constant. These affect the travel time of each wavelength through the fiber medium. An initially narrow pulse is widened as a result of this, and as the pulses spread, they begin to overlap, causing the bit error rate to increase.

High data rates mean pulses are closely spaced in time and have less room to spread before they overlap. High channel count increases the difficulty in correcting dispersion since each channel experiences different levels of dispersion.

Long distances between regenerators require that dispersion be managed very precisely because the effects accumulate over distance. As link length and bit rate increase, the effects of chromatic dispersion also increase. Chromatic dispersion is therefore one of the main factors limiting data transfer for modern optical networks.

Typical Applications

Getting precise chromatic dispersion parameters helps you select the right dispersion-compensated fiber or material in order to reverse the dispersion and dispersion slope before data are interpreted by the receiver.

Conventions

Before using the product described in this manual, you should understand the following conventions:



WARNING

Indicates a potentially hazardous situation which, if not avoided, could result in *death or serious injury*. Do not proceed unless you understand and meet the required conditions.



CAUTION

Indicates a potentially hazardous situation which, if not avoided, may result in *minor or moderate injury*. Do not proceed unless you understand and meet the required conditions.



CAUTION

Indicates a potentially hazardous situation which, if not avoided, may result in *component damage*. Do not proceed unless you understand and meet the required conditions.



IMPORTANT

Refers to information about this product you should not overlook.

2 **Getting Started with Your Chromatic Dispersion Analyzer**



IMPORTANT

The power consumption of the module is relatively high. Therefore, it is not recommended to use it with battery or to activate other power consuming modules at the same time on the platform.

Inserting and Removing Test Modules



CAUTION

Never insert or remove a module while the FTB-500 Universal Test Platform is turned on. This will result in immediate and irreparable damage to both the module and unit.



WARNING

When the laser safety LED () is flashing on the FTB-500, at least one of your modules is emitting an optical signal. Please check all modules, as it might not be the one you are currently using.

To insert a module into the FTB-500 Universal Test Platform:

1. Exit ToolBox and turn off your unit.
2. Position the FTB-500 so that its right panel is facing you.

Getting Started with Your Chromatic Dispersion Analyzer

Inserting and Removing Test Modules

3. Take the module and place it so that the connector pins are at the back, as explained and shown below.

Identification sticker must be facing up and connector pins at the right of the retaining screw hole.

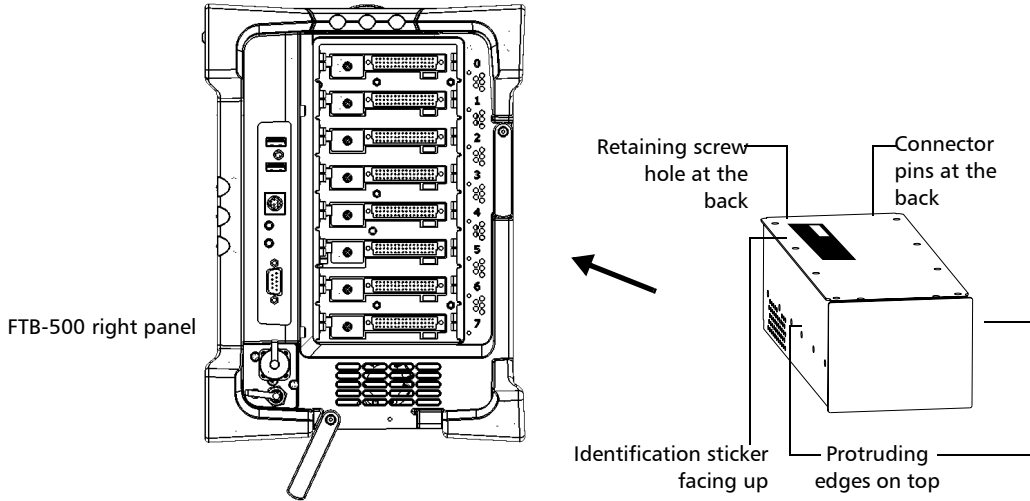

4. Insert the protruding edges of the module into the grooves of the receptacle's module slot.
5. Push the module all the way to the back of the slot, until the retaining screw makes contact with the receptacle casing.
6. Place the FTB-500 so that its left panel is facing you.

Getting Started with Your Chromatic Dispersion Analyzer

Inserting and Removing Test Modules

7. While applying slight pressure to the module, turn the retaining screw clockwise until it is tightened.

This will secure the module into its “seated” position.

Turn retaining screw knob
clockwise

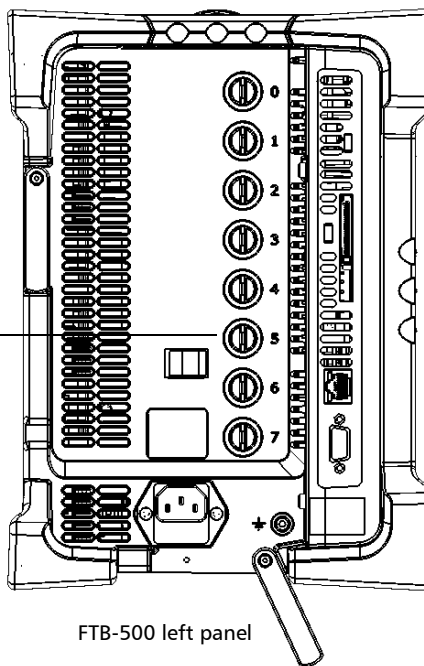
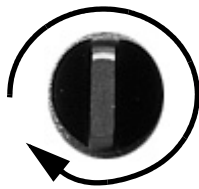

FTB-500 left panel

When you turn on the unit, the startup sequence will automatically detect the module.

Getting Started with Your Chromatic Dispersion Analyzer

Inserting and Removing Test Modules

To remove a module from the FTB-500 Universal Test Platform:

1. Exit ToolBox and turn off your unit.
2. Position the FTB-500 so that the left panel is facing you.
3. Turn the retaining screw counterclockwise until it stops.

The module will be slowly released from the slot.

Turn retaining screw knob(s)
counterclockwise

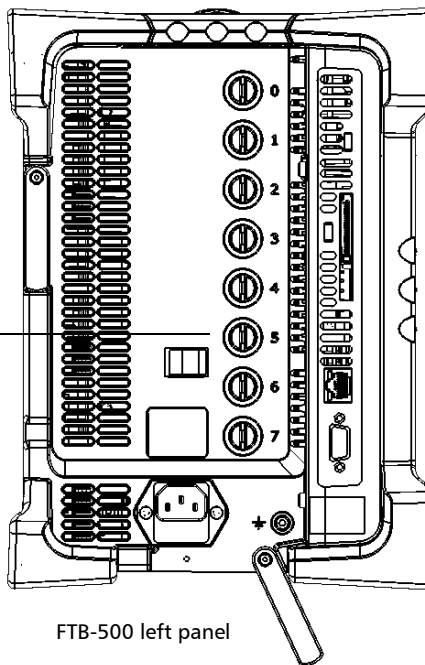
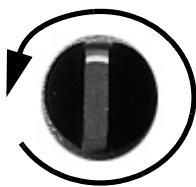

FTB-500 left panel

4. Place the FTB-500 so that the right panel is facing you.

Getting Started with Your Chromatic Dispersion Analyzer

Inserting and Removing Test Modules

5. Hold the module by its sides or by the handle (*NOT by the connector*) and pull it out.

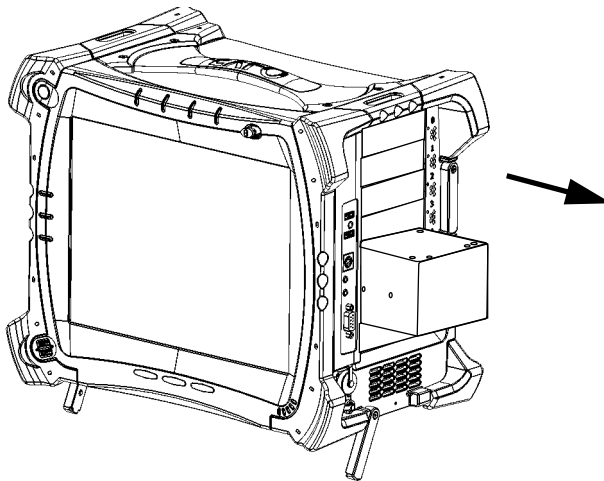

Getting Started with Your Chromatic Dispersion Analyzer

Starting the Chromatic Dispersion Analyzer Application

Starting the Chromatic Dispersion Analyzer Application

Your FTB-5800 Chromatic Dispersion Analyzer module can be configured and controlled from its dedicated ToolBox application.

Note: For details about ToolBox, refer to the FTB-500 user guide.

To start the application:

1. From the main window, select the module to use.

It will turn blue to indicate that it is highlighted.

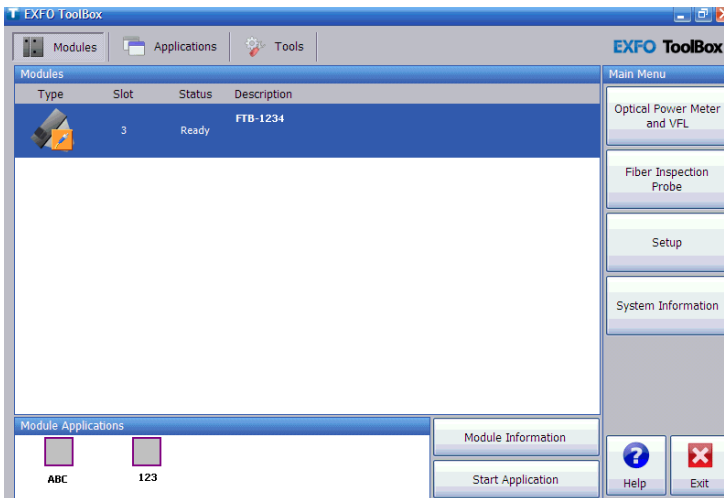

2. Click the corresponding button in the **Module Applications** box.

Getting Started with Your Chromatic Dispersion Analyzer

Starting the Chromatic Dispersion Analyzer Application

The main window (shown below) contains all the commands required to control the Chromatic Dispersion Analyzer:

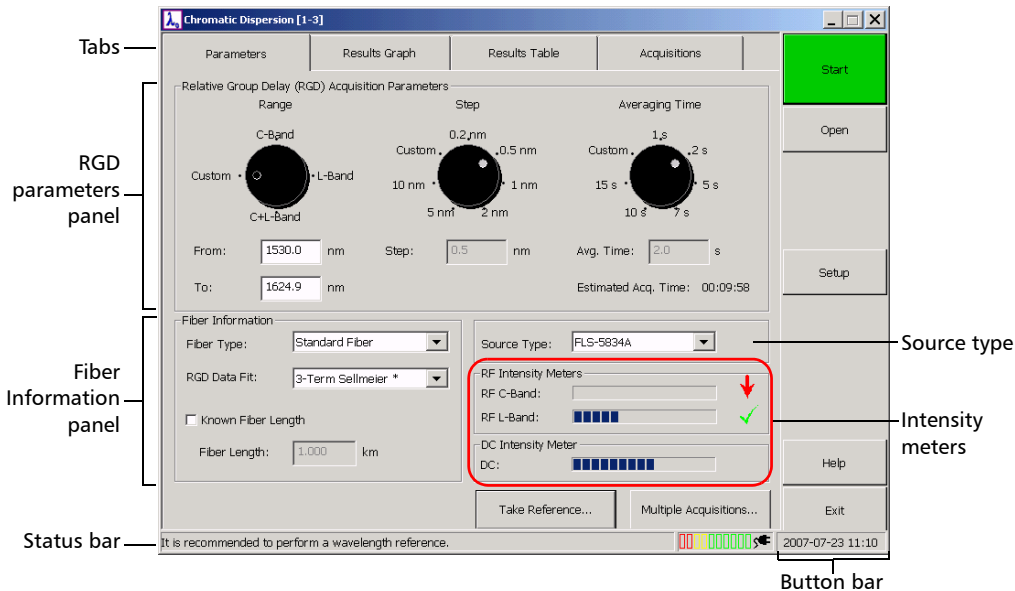

Getting Started with Your Chromatic Dispersion Analyzer

Exiting the Application

Status Bar

The status bar, located at the bottom of the main window, identifies the operational status of the FTB-5800 Chromatic Dispersion Analyzer.

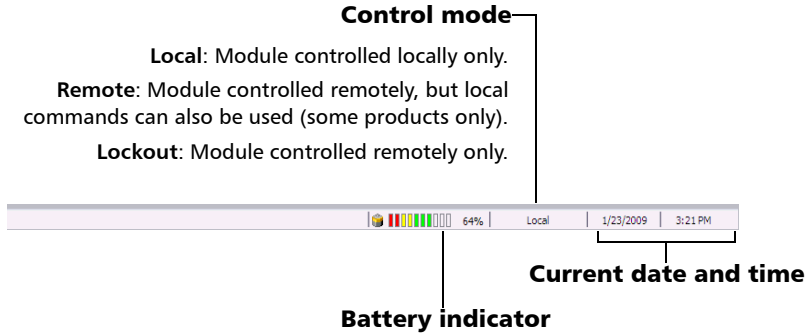

For more information about automating or remotely controlling the FTB-5800 Chromatic Dispersion Analyzer, refer to your platform user guide.

Exiting the Application

Closing any application that is not currently being used helps freeing system memory.

To close the application from the main window:

Click  in the top right corner of the main window.

OR

Click the **Exit** button located at the bottom of the function bar.

3 **Setting Up Your Chromatic Dispersion Analyzer**

The parameters you set will be kept in memory after turning off the FTB-500 Universal Test Platform.

Setting the Wavelength Range

You can set the wavelength range within which you want to perform your acquisitions. You can work with predefined bands (C, L or C+L) or set the wavelength range by using the custom option. This option could be useful to perform acquisitions in a specific area of a band or between two bands.



IMPORTANT

Make sure you connect the source corresponding to the wavelength range you select at the other end of the link.

To select a predefined wavelength range:

On the **Parameters** tab, use the **Range** dial.

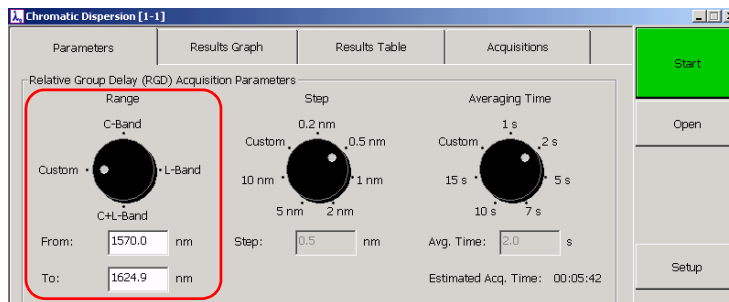

To set the wavelength range using the custom option:

1. On the **Parameters** tab, set the **Range** dial to **Custom**.
2. Enter your values in the **From:** and **To:** boxes. The values you enter must be between 1530 and 1625 nm, which are, respectively, the lower limit of the C band and the upper limit of the L band.

Setting Up Your Chromatic Dispersion Analyzer

Setting the Wavelength Step

The wavelength step corresponds to the interval, in nanometers, at which the system will take RGD measurements within the selected wavelength range. You can either select one of the preprogrammed step or specify the desired value with the custom option.

Note: *The smaller the step you select, the higher the accuracy of your measurement will be and the longer the acquisition will take. For unknown fiber type or amplified links, EXFO strongly recommends selecting the smallest step possible.*

To select a predefined wavelength step:

On the **Parameters** tab, use the **Step** dial.



To set the wavelength step using the custom option:

- 1.** In the **Parameters** tab, set the **Step** dial to **Custom**.
- 2.** Enter the desired value in the **Step** box. The value must be between 0.1 nm and the wavelength range you chose previously.

Moreover, the final measurement point, may not correspond to the upper limit of the wavelength range if the wavelength span

$$\lambda_{\max} - \lambda_{\min}$$

is not an integer value of

$$\Delta\lambda$$

A warning message will indicate if your step is too small or too large.

Setting Up Your Chromatic Dispersion Analyzer

Setting the Averaging Time

The averaging time is the time the system spends on one specific point or wavelength. You can either select one of the preprogrammed values or specify the desired averaging time with the custom option.

Note: *The stronger the signal, the faster a signal-to-noise ratio (SNR) will be reached. If your signal is weak, increase the averaging time in order to increase the accuracy of your results. Beyond a certain time limit, however, the accuracy you gain will be insignificant.*

To select a predefined averaging time:

On the **Parameters** tab, use the **Averaging Time** dial.

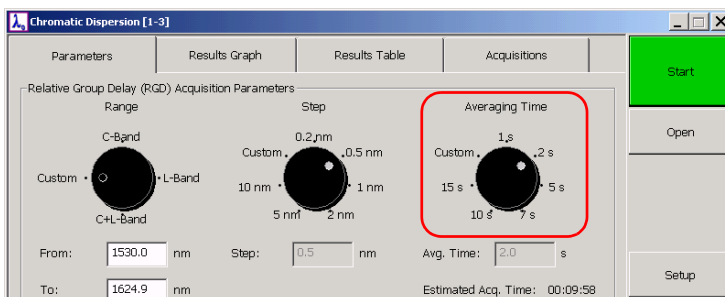

To set averaging time using custom option:

1. In the **Parameters** tab, set the **Averaging Time** dial to **Custom**.
2. Enter a value between 1.0 s and 60.0 s in the **Avg Time** box. The system will warn you if the value exceeds those limits.

Note: *The averaging time displayed on the screen does not take stabilizing time into account. The **Estimated Acq. Time** box will give you an idea of the overall time your acquisition will take, including the time needed for the system to stabilize, as this time can vary.*

Specifying the Fiber Under Test

Before making an acquisition, you must also enter information on the fiber you are going to test. This information includes the fiber type, the data fit, and the fiber length. You can also specify the distance units to be used.

Whether you know the fiber length or not will affect your results display.

- Unknown fiber length: results will show the total dispersion.
- Known fiber length: results will give out the dispersion per kilometer.

Note: *The units you modify are only used when you specify the fiber length. On the scales, as well as for calculation, the distance will always remain in kilometers.*

Setting Up Your Chromatic Dispersion Analyzer

Specifying the Fiber Under Test

To specify the fiber under test:

In the **Parameters** tab, under **Fiber Information**, set the fiber parameters.

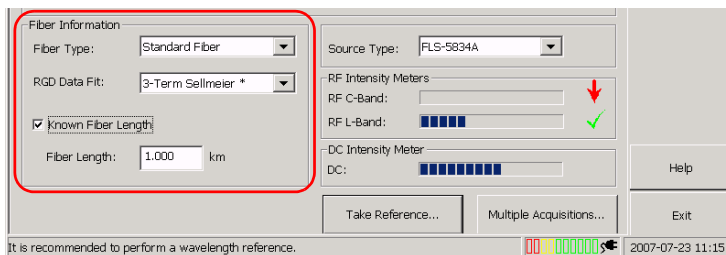

- In the **Fiber Type** list, select the appropriate value.

Note: If you do not know the fiber type, select “**Unknown Fiber Type**”. If your fiber is made of more than one type of fiber, either enter the dominant fiber type or select “**Unknown Fiber Type**”.

- The application will designate a default fit according to the fiber type; it will be marked by an asterisk (*) to indicate that it is a default value. If necessary, in the **RGD Data Fit** list, select the desired data fit.

Note: The RGD data fit you select here will be applied to the relative group delay for the next acquisition. However, once in the Results Graph tab, it is possible to interpret your results by selecting another fit.

- If you know the fiber length, select the **Known Fiber Length** box and enter the appropriate fiber length in the corresponding box. By default, the value is in kilometers.

To modify the distance units:

1. On the button bar, click the **Setup** button, to access the **Application Setup** dialog box.

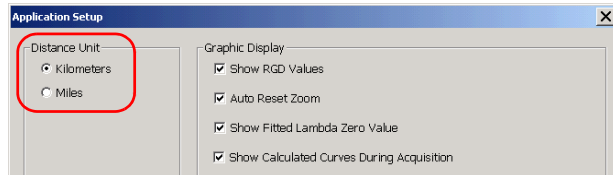

2. Under **Distance Unit**, select the desired units.
3. Click **OK** to confirm the new settings or **Cancel** to discard them.

Setting Up Your Chromatic Dispersion Analyzer

Defining the Automatic Fiber Name Format

Defining the Automatic Fiber Name Format

Each time you make a new acquisition, the fiber name changes automatically according to a pattern you will have previously defined. This name is made of a static part (prefix) and a variable part that will be incremented.

The increment can be positive, negative or null (zero). Entering zero gives you the opportunity to use the same acquisition fiber name.

Note: *The number you can enter will depend on the number of digits you have specified. For example, if you set two digits, the maximum you can enter is 99. Once the system reaches 99, it will step back to 00. If the selected increment is negative, when the system reaches 00, it will step back to 99.*

If you do not enter any prefix or number, the fiber will be identified with one number only.

Note: *You can modify the fiber name later, when the acquisitions are complete. For more information, see Documenting Results on page 59.*

Note: *You cannot define the automatic fiber name format in offline mode.*

Setting Up Your Chromatic Dispersion Analyzer

Defining the Automatic Fiber Name Format

To define the fiber name format:

- 1.** On the button bar, click **Setup**.
- 2.** Under **Autonaming**, set the various parameters according to your needs.

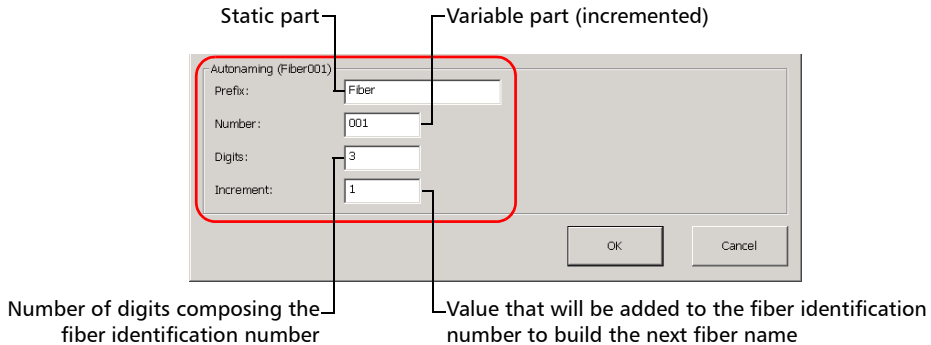

4 Operating Your Chromatic Dispersion Analyzer

Installing the EXFO Universal Interface (EUI)

The EUI fixed baseplate is available for connectors with angled (APC) or non-angled (UPC) polishing. A green border around the baseplate indicates that it is for APC-type connectors.

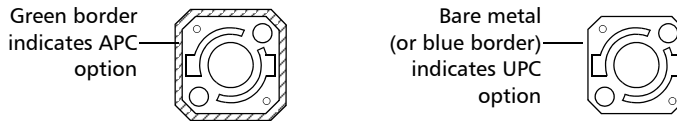

To install an EUI connector adapter onto the EUI baseplate:

1. Hold the EUI connector adapter so the dust cap opens downwards.

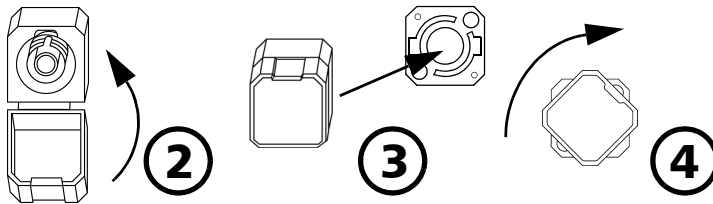

2. Close the dust cap in order to hold the connector adapter more firmly.
3. Insert the connector adapter into the baseplate.
4. While pushing firmly, turn the connector adapter clockwise on the baseplate to lock it in place.

Cleaning and Connecting Optical Fibers



IMPORTANT

To ensure maximum power and to avoid erroneous readings:

- Always inspect fiber ends and make sure that they are clean as explained below before inserting them into the port. EXFO is not responsible for damage or errors caused by bad fiber cleaning or handling.
- Ensure that your patchcord has appropriate connectors. Joining mismatched connectors will damage the ferrules.

To connect the fiber-optic cable to the port:

- 1.** Inspect the fiber using a fiber inspection microscope. If the fiber is clean, proceed to connecting it to the port. If the fiber is dirty, clean it as explained below.
- 2.** Clean the fiber ends as follows:
 - 2a.** Gently wipe the fiber end with a lint-free swab dipped in isopropyl alcohol.
 - 2b.** Use compressed air to dry completely.
 - 2c.** Visually inspect the fiber end to ensure its cleanliness.

Operating Your Chromatic Dispersion Analyzer

Cleaning and Connecting Optical Fibers

3. Carefully align the connector and port to prevent the fiber end from touching the outside of the port or rubbing against other surfaces.

If your connector features a key, ensure that it is fully fitted into the port's corresponding notch.

4. Push the connector in so that the fiber-optic cable is firmly in place, thus ensuring adequate contact.

If your connector features a screwsleeve, tighten the connector enough to firmly maintain the fiber in place. Do not overtighten, as this will damage the fiber and the port.

Note: *If your fiber-optic cable is not properly aligned and/or connected, you will notice heavy loss and reflection.*



IMPORTANT

The FTB-5800 module is particularly sensitive to unclean fibers. Your results can be erroneous if your fiber is dirty. Verify the fiber end with a portable fiber-optic microscope (for example, EXFO's FOMS) or fiber inspection probe (for example, EXFO's FIP).



WARNING

Verifying the fiber end **WHILE THE SOURCE IS ACTIVE** WILL result in permanent eye damage.

Selecting the Source Type

Different sources can be used for testing with your Chromatic Dispersion Analyzer. The different sources allow you work on either the C-band, the L-band or the C+L-bands.

Source Type	Available Bands
FLS-5834, FLS-5804, FLS-5803	C, L, C+L
FLS-5834A	C+L

Note: *If you change the source type, you must perform a new reference measurement. For details, see Performing Reference Measurements on page 28.*

To select the source type:

On the **Parameters** tab, select the desired source in the corresponding list.

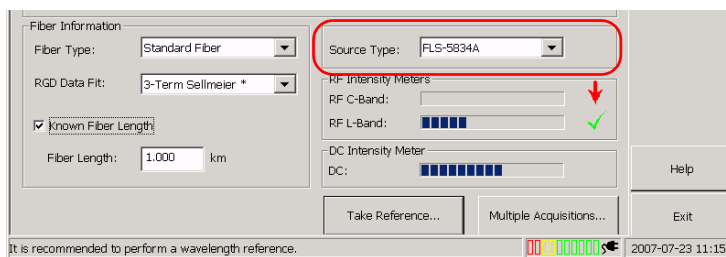

Verifying the Intensity of the Source

The intensity meters allow you to make sure a source is connected to the other end of the link and that this source corresponds to the band you are testing.

RF Intensity Meter indicates...	Possible causes/solution
Power too low (Signal is too weak to be measured)	<ul style="list-style-type: none"> ➤ Source is not active. ➤ Source is active but in the wrong bandwidth. ➤ Connected source is not an FLS-5800 CD/PMD Analyzer Source. ➤ Source is defective. ➤ Discontinuities in the optical link. ➤ High-frequency modulation of the optical signal has been overly reduced because of a saturated EDFA.
Power too high (Signal is too strong to be measured)	<ul style="list-style-type: none"> ➤ Use the High Power port instead of the Low Power port. ➤ Use an attenuator with a null dispersion to take your measurement. For more information, please contact EXFO.

To verify the intensity of the source:

On the **Parameters** tab, consult the **RF Intensity Meters** indicators. Green check marks indicate an appropriate intensity. Up or down arrows indicate that the intensity is respectively too low or too high. You can also check DC intensity from the **DC Intensity Meter**.

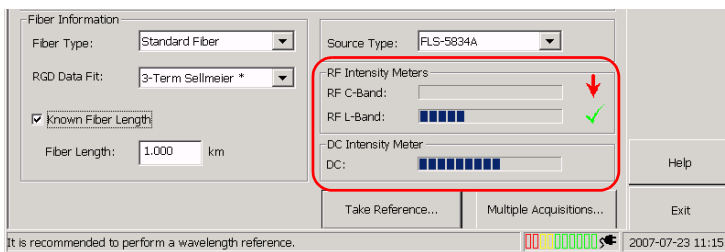

Performing Reference Measurements



IMPORTANT

To ensure the best possible results, EXFO recommends performing reference measurements for wavelength and for chromatic dispersion. Furthermore, you must perform a wavelength reference **BEFORE** performing the chromatic dispersion reference.

Skipping wavelength reference may lead to inaccurate results. You cannot perform both references in a single step.

Operating Your Chromatic Dispersion Analyzer

Performing Reference Measurements

Reference type	Recommended reference frequency	Remarks
Wavelength	Before each test session and every time the application recommends it.	<ul style="list-style-type: none">➤ Adjusts the source wavelength precisely.➤ The application will advise you to take a wavelength reference whenever the need arises (after selecting a different source type, after module initialization, after a certain period of time or when temperature varies), but never during acquisitions. <p>When references are necessary, a message will appear in the status bar, recommending a new reference.</p>
Chromatic dispersion	Once every month and every time the source or patchcord is changed.	<ul style="list-style-type: none">➤ Used to cancel out source, analyzer and patchcord dispersion. It will be taken according to the sources you have selected (C-source; C-reference).➤ Important for low-chromatic-dispersion measurement.

Operating Your Chromatic Dispersion Analyzer

Performing Reference Measurements

To take a wavelength reference:

Note: If the application has prompted you for a wavelength reference (after initialization), you will be brought to step 3 of this procedure automatically.

1. Ensure that the fiber is properly connected to the Ref/High Power port.
2. On the **Parameters** tab, click the **Take Reference** button.

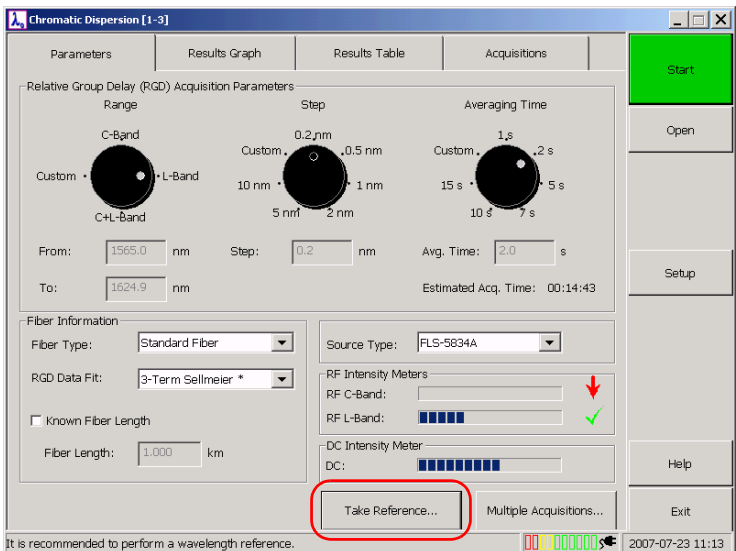

3. On the **Wavelength** tab, select the source band corresponding to the source you intend to use.

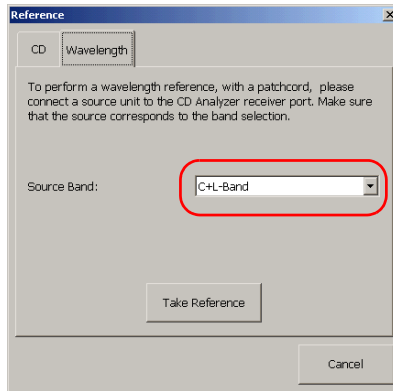

4. Once your information is entered, click **Take Reference**.

Operating Your Chromatic Dispersion Analyzer

Performing Reference Measurements

To take a chromatic dispersion reference:

1. Ensure that a wavelength reference has been performed.
2. Ensure that the fiber is properly connected to the Ref/High Power port.
3. In the **Parameters** tab, click the **Take Reference** button.

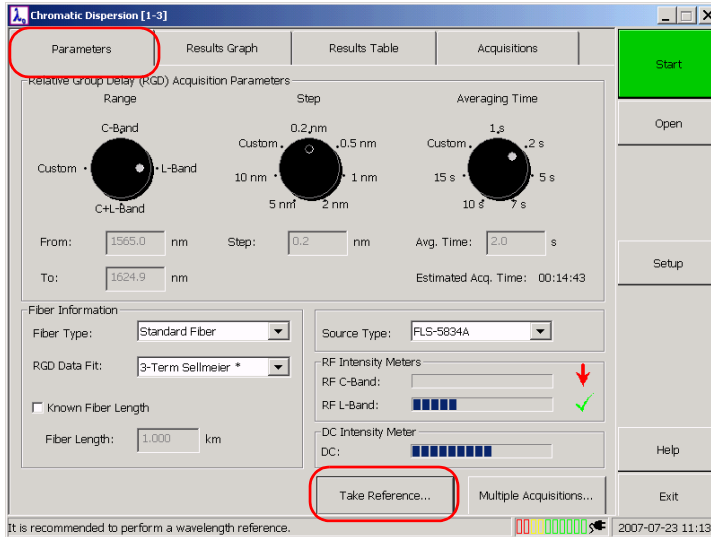

4. On the **CD** tab, identify the source from which the reference will be taken. In the following dialog box, enter the source model and source serial number in the appropriate boxes. This data will also be displayed on the **Results Table** tab in the application main window.

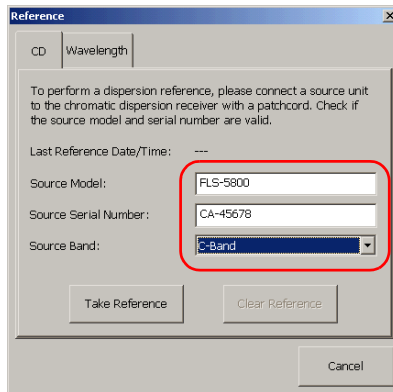

5. Once your information is entered, click the **Take Reference** button.

Note: *There is no reference setup, so the reference will be valid for all kinds of tests using various parameters.*

Operating Your Chromatic Dispersion Analyzer

Applying a Chromatic Dispersion Reference

Applying a Chromatic Dispersion Reference

Chromatic dispersion references can be taken after the results have been acquired. This is useful if you did not have a source and patchcords at hand before performing acquisitions (source and Chromatic Dispersion Analyzer can be many kilometers apart).

Once your reference is taken, you can apply it to your results. The patchcord and analyzer dispersion will be subtracted from your results. For more information on references and their importance, see *Performing Reference Measurements* on page 28.



IMPORTANT

The reference will be applied to the entire file, not only to the specific acquisition that is selected.

To apply a chromatic dispersion reference to your results:

1. On the **Acquisitions** tab, select any line.

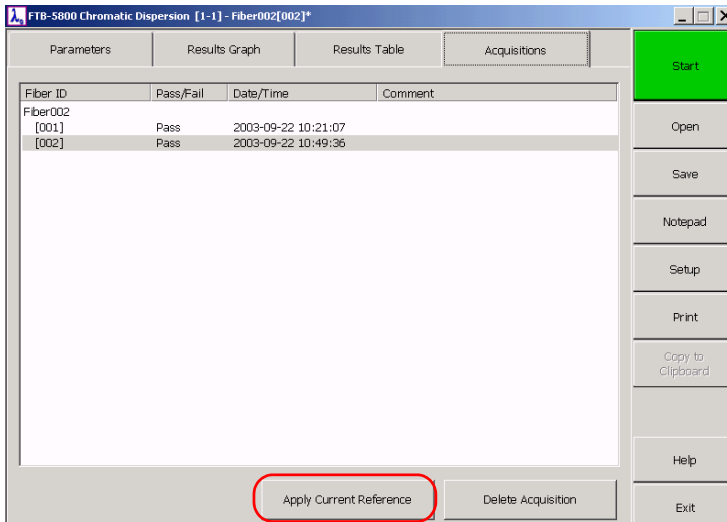

2. Click the **Apply Current Reference** button.

Creating a File

Each time you make an acquisition, the results are added to those already displayed under the **Application** tab. By default, when you save your results, they will be all stored in the same file. If you want your results to be stored in different files, you must explicitly create a new file BEFORE making a new acquisition or set of acquisitions.

To create a file:

1. On the button bar, click **Open**.
2. In the **Open File** dialog box, click **New File**.

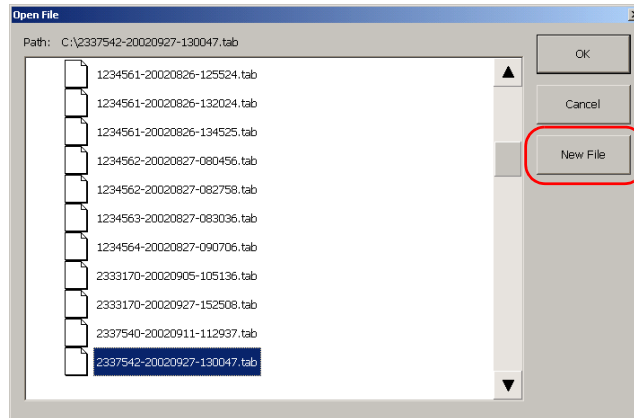

You are now ready to perform acquisitions.

Measuring Chromatic Dispersion

You can perform both single and multiple acquisitions on fibers.

To perform multiple acquisitions on the same fiber you must define the number of measurements and the interval between them.

The average time between acquisitions must be of at least five minutes. The five-minute period takes into account the time the application might take to characterize the fiber link, depending on the quality of the signal. In order for the value entered here to be valid, you must add five minutes to the estimated acquisition time.



IMPORTANT

Do not change the test fiber between two acquisitions of a multiple-measurement test since parameters set for a specific fiber may not apply to all fibers.

If you stop an acquisition before it is complete, the results acquired until then will be displayed. However, in some cases, a minimum number of points must be acquired for the application to calculate chromatic dispersion and display a trace (for example, at least three points for the 3-Term Sellmeier type and at least five for the 5-Term Sellmeier).

To perform single or multiple acquisitions on a fiber:

1. If necessary, create a file (see *Creating a File* on page 35).
2. Set the general acquisition parameters as explained in *Setting Up Your Chromatic Dispersion Analyzer* on page 13.
3. On the **Parameters** tab, click the **Multiple Acquisitions** button to access the parameters dialog box.

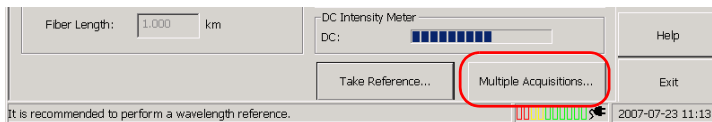

4. Set the parameters.

- Single acquisition: clear the **Multiple Acquisitions** check box.

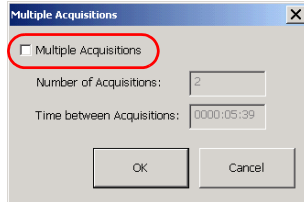

- Multiple acquisitions: select the **Multiple Acquisitions** box and set the parameters.

5. Click **OK** to confirm.

- 6.** Verify that the fiber is properly connected and that the source is activated in the right band.

Operating Your Chromatic Dispersion Analyzer

Measuring Chromatic Dispersion

7. On the button bar, click **Start**.

The **Start** button becomes a red **Stop** button. The application automatically goes to the **Results Graph** tab. You can move to the **Results Table** tab to see your results.

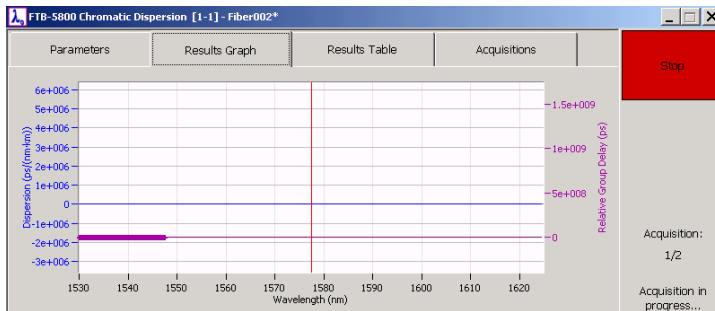

Note: The application takes some time to evaluate the power of the source. The stronger the signal, the shorter the acquisition.

To stop the acquisition before it is complete:

Click the **Stop** button. The button changes back to a green **Start** button.

Saving Your Results

Once your acquisition is done, you must save your results if you intend to use them for further analysis later on.

Note: *If the file has not been saved yet or if some changes have been made to a saved file, an asterisk appears beside the filename in the title bar.*



IMPORTANT

When the application saves the results, all the acquisitions present under the Acquisition tab will be stored in the same file. Consequently, if you have opened an already existing file, the results of the new acquisitions will be appended to this file.

If you want your results to be stored in different files, you must explicitly create a new file BEFORE making a new acquisition or set of acquisitions (see *Creating a File* on page 35).

The application will prompt you if you have not saved the results before creating a new file or exiting.

To save your results:

1. On the button bar, click the **Save** button.

Note: *If a keyboard is connected to the FTB-500, you can also use the Ctrl+S shortcut key to save your results.*

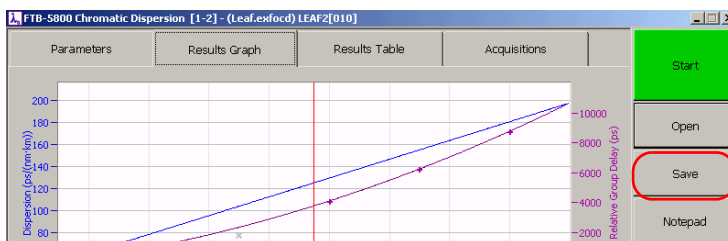

Operating Your Chromatic Dispersion Analyzer

Saving Your Results

2. Select the folder in which you want to save your data or create a folder by clicking the **New Folder** button.

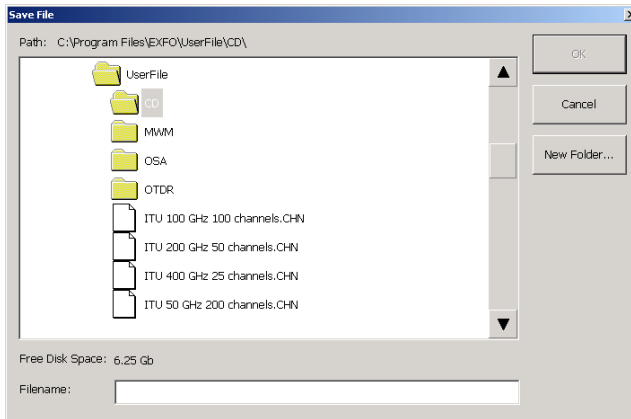

3. In the **Filename** box, type the name you want to give to your file (if the virtual keyboard is not displayed, select the **Filename** box again.) The file format is xxx.ExfoCD.
4. Click **OK**.

You know that the file is saved when the asterisk beside the name disappears.

5 ***Managing Results***

Your FTB-5800 Chromatic Dispersion Analyzer allows you to work with two types of results:

- Newly acquired results
- Results loaded from existing files

To view and analyze your results, the application provides:

- A graph and a table presenting details for a specific acquisition
- A window giving you an overview of all the available acquisitions

You can zoom in on specific areas of the graph or remove points that are too far from the average. You can also specify which curves will be displayed (dispersion, RGD).

Finally, the Chromatic Dispersion Analyzer allows you to print or to export results and related information.

Managing Results

Recalling a Saved File

Recalling a Saved File

It is possible to reload existing files in *.exfocd* format. These files can also be opened directly from Windows Explorer (the Chromatic Dispersion Analyzer application starts automatically).

To open a file from the Chromatic Dispersion Analyzer:

1. On the button bar, click the **Open** button to recall the desired file.

Note: If a keyboard is connected to the FTB-500, you can also use the *Ctrl+O* shortcut key to open your file.

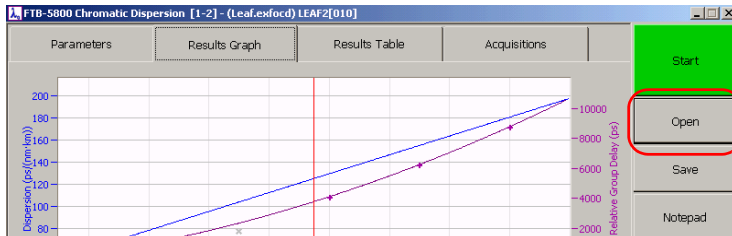

2. Select the file and click **OK**.

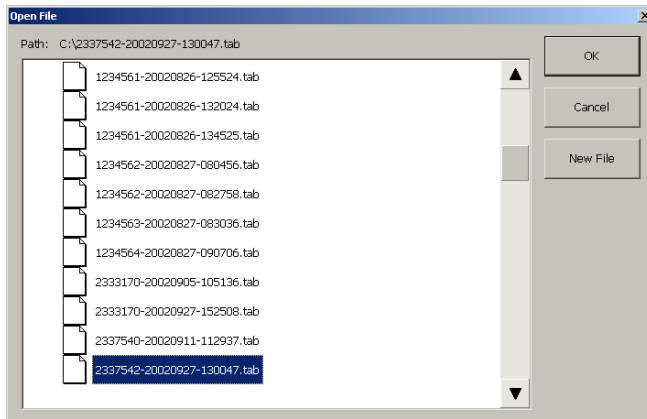

Analyzing Results from the Results Graph

The application presents a graph containing details about the current acquisition, including the fitted lambda zero value (extrapolated wavelength at which the dispersion equals 0), the dispersion, the RGD curve (illustrating the fitted points) and the measured RGD points. The fitted lambda zero value, the RGD curve and the RGD points can be shown or hidden, according to your needs.

The graph is based on three scales:

- **Dispersion scale:** displays results in ps/nm-km or in ps/nm if the fiber length is not known or not entered.
- **Relative Group Delay (RGD):** displays results in ps.
- **Wavelength:** displays the wavelength in nm.

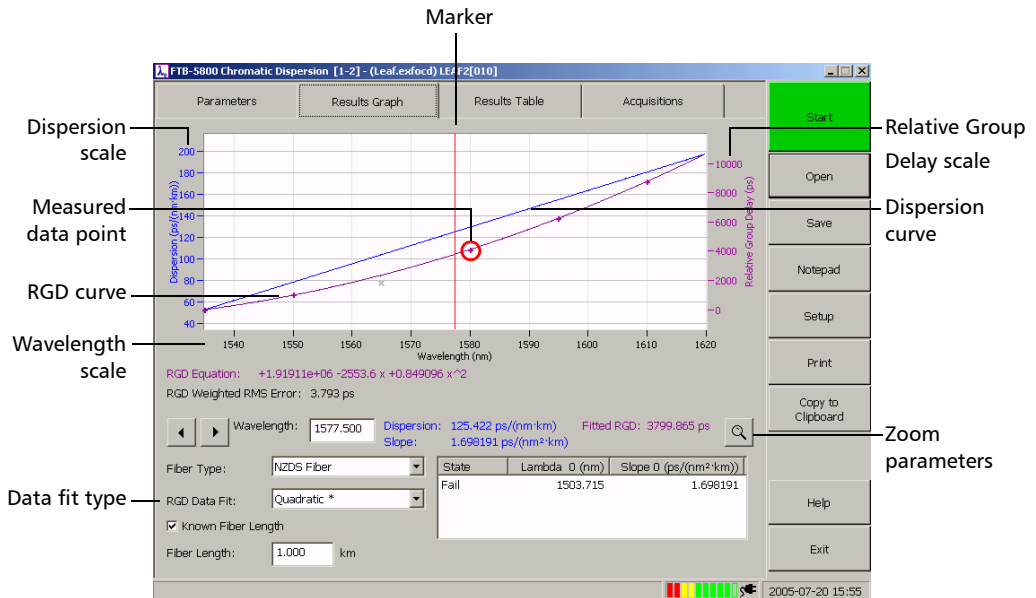

Managing Results

Analyzing Results from the Results Graph

Even if you have acquired your results with a particular type of data fitting, during your analysis, you may want to apply another type of fit. You should select the type of fit you want to apply to your results carefully so as to minimize error. Some types of fits such as the Cubic and 5-Term Sellmeier should not be used to extrapolate data.

Note: *A minimum amount of points must be acquired for the fit to be calculated and for the dispersion to be displayed. The minimum number of points varies according to the fit.*

The Chromatic Dispersion Analyzer also provides you with tools to help you focus on certain data in the graph.

- You can set the marker to a specific point of the graph to view the results related to this point. Once you have positioned the marker, it will keep its position for the next acquisition.
- You can zoom in on specific areas of the graph to have a better view or zoom out to see extrapolated data. It is also possible to revert to default zoom manually or automatically when the corresponding option is activated.

In some cases, it is useful to deactivate the automatic zoom reset. For example, if you are analyzing a file containing many acquisitions, it allows you to define the zoom once and then apply it to all traces. Otherwise, you would have to define the zoom for each trace.

To show or hide the fitted lambda zero value:

1. On the button bar, click **Setup**.

2. Under **Graphic Display**,

select the **Show Fitted Lambda Zero Value** check box to show the value.

OR

clear the **Show Fitted Lambda Zero Value** check box to hide the value.

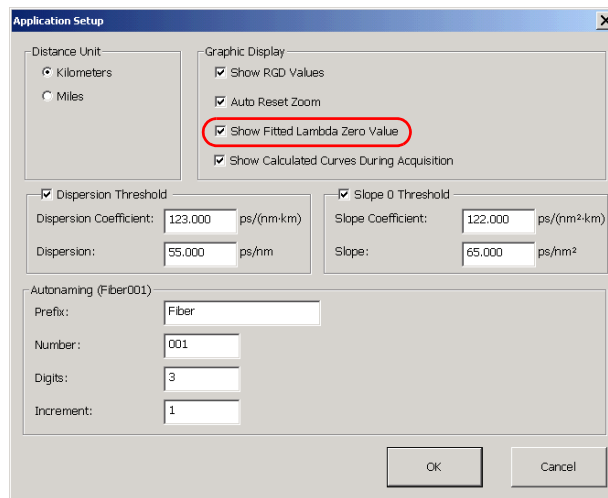

Confirm the changes with **OK**.

Managing Results

Analyzing Results from the Results Graph

To show or hide the RGD curves and/or RGD values

1. On the button bar, click **Setup**.
2. Under **Graphic Display**,

Click the **Show RGD Values** and/or **Show Calculated Curves During Acquisition** check boxes to show the corresponding elements.

OR

Clear the **Show RGD Values** and/or **Show Calculated Curves During Acquisition** check boxes to hide the corresponding elements.

The screenshot shows the 'Application Setup' dialog box with the following settings:

- Distance Unit:** Kilometers, Miles
- Graphic Display:**
 - Show RGD Values
 - Auto Reset Zoom
 - Show Fitted Lambda Zero Value
 - Show Calculated Curves During Acquisition
- Dispersion Threshold:**
 - Dispersion Threshold
 - Dispersion Coefficient: 123.000 ps/(nm-km)
 - Dispersion: 55.000 ps/nm
- Slope 0 Threshold:**
 - Slope 0 Threshold
 - Slope Coefficient: 122.000 ps/(nm²-km)
 - Slope: 65.000 ps/nm²
- Autonaming (Fiber001):**
 - Prefix: Fiber
 - Number: 001
 - Digits: 3
 - Increment: 1

Buttons: OK, Cancel

3. Click **OK**.

To interpret results using a different type of fit:

On the **Results Graph** tab, in the **RGD Data Fit** list, select the desired type of fit.

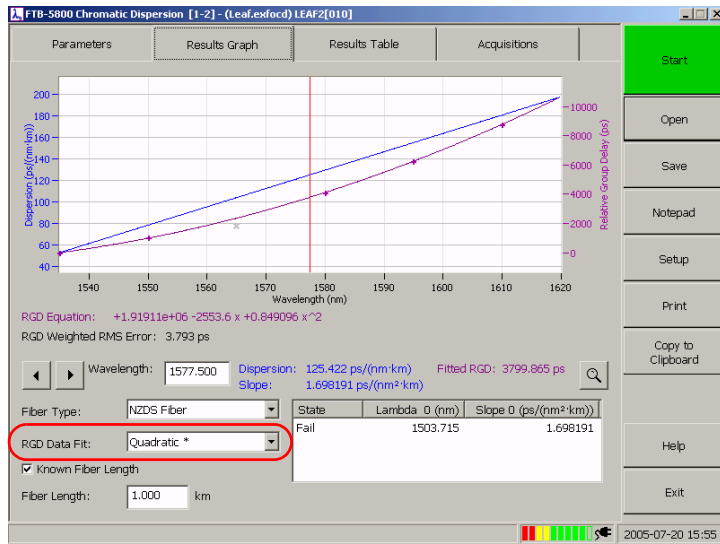

Managing Results

Analyzing Results from the Results Graph

To position the marker:

- Drag the marker to the point you want to focus on.
- Use the right and left arrows to move the marker to the desired position.
- Select the marker and move it with the FTB-500 selection dial.

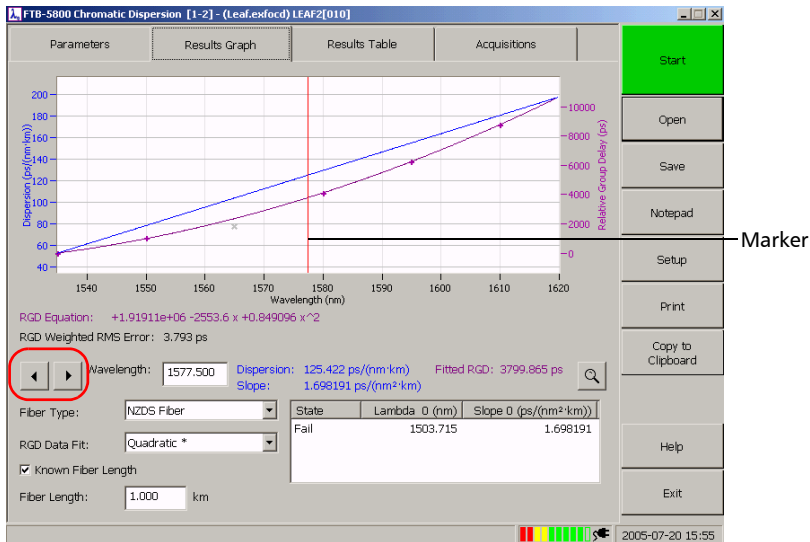

To zoom in on results or zoom out:

1. On the **Results Graph** tab, click the magnifying glass button.

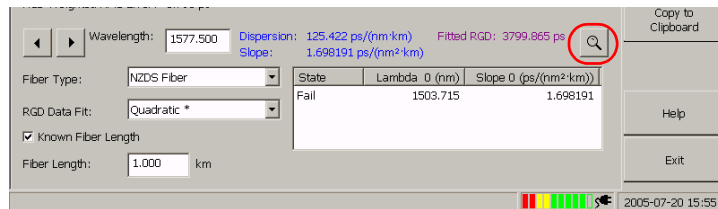

2. Enter the desired range by putting a lower and upper limit value in the boxes of your choice. The wavelength, dispersion and RGD will be magnified accordingly.

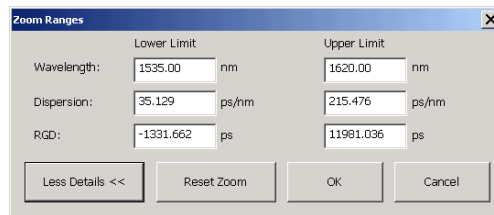

Note: You can only use the zoom function on extrapolated values that are within the 1200 to 1700 nm wavelength acquisition range. Extrapolated values are representative of the selected fit and might not represent the true behavior of the fiber.

- In the first level, you can enter the wavelength values you want to see extrapolated in the **Lower Limit** and **Upper Limit** boxes.
- You can also click **More Details** to access to additional parameters for the zoom function. Enter the **Dispersion** or **RGD** value you want to see extrapolated, in the **Lower Limit** and **Upper Limit** boxes.

3. When you are done, click **OK**.

Managing Results

Analyzing Results from the Results Graph

To revert the zoom factor to its default value:

1. On the **Results Graph** tab, click the magnifying glass button.

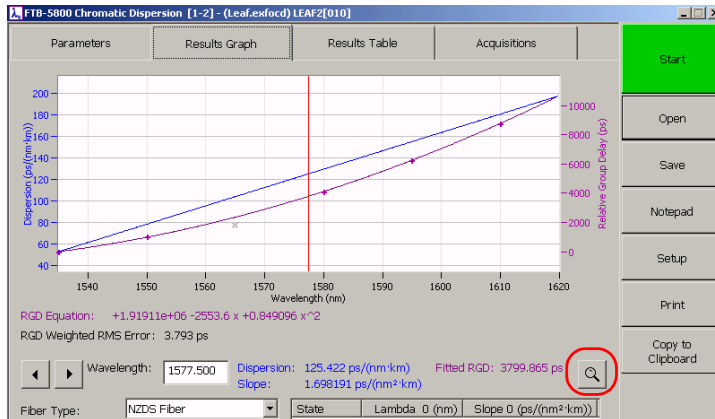

2. Click the **Reset Zoom** button to reset the graph view so that all the acquisition points are visible.

The screenshot shows the 'Zoom Ranges' dialog box. It has a title bar 'Zoom Ranges' and a close button 'X'. The dialog box contains three rows of input fields for Lower Limit and Upper Limit. The first row is for Wavelength (nm), with values 1535.00 and 1620.00. The second row is for Dispersion (ps/nm), with values 35.129 and 215.476. The third row is for RGD (ps), with values -1331.662 and 11981.036. At the bottom, there are four buttons: 'Less Details <<', 'Reset Zoom', 'OK', and 'Cancel'. The 'Reset Zoom' button is circled in red.

To have the zoom reset automatically:

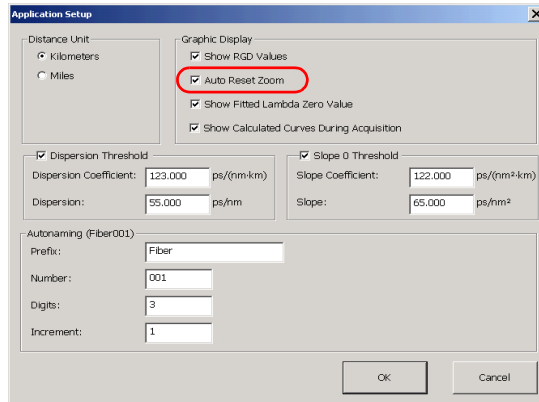

1. On the button bar, click **Setup**.
2. Under **Graphic Display**, select the **Auto Reset Zoom** check box.



Analyzing Results from the Results Table

The columns presented on the **Results Table** tab are detailed below. They show you part of the data you need to know to analyze your results. The content of the table can also be sorted for easier management.

- The first column indicates if the data in this row is used to calculate the final results.
- **Wavelength:** indicates the wavelength at which the dispersion has been calculated.
- **RGD:** corresponds to the measured relative group delay.
- **Fitted RGD:** corresponds to the relative group delay obtained from the fitted curve over the measured RGD.
- **RGD Deviation:** corresponds to the absolute value between the RGD and the Fitted RGD.
- **Dispersion (ps/nm):** Dispersion value when fiber length is unknown.
- **Dispersion (ps/nm-km):** Coefficient of dispersion when fiber length is known.

When applicable, in the dispersion and coefficient of dispersion columns, the acquisition status is indicated by  (pass) or  (fail). For more information, see *Establishing Thresholds* on page 56.

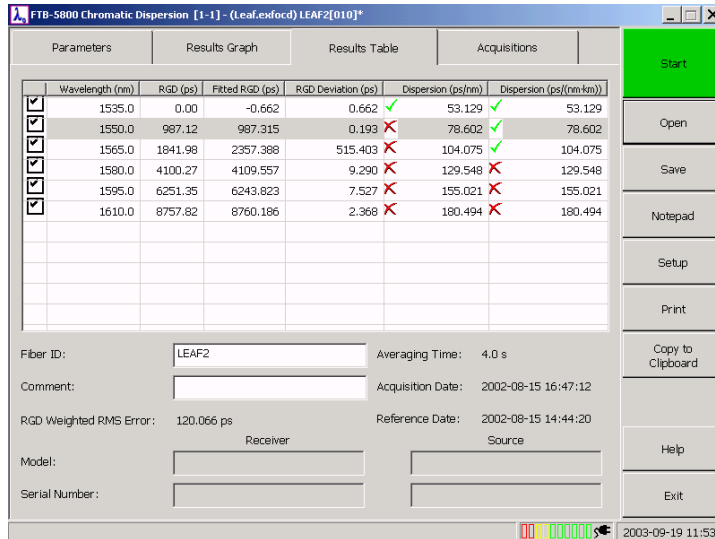

	Wavelength (nm)	RGD (ps)	Fitted RGD (ps)	RGD Deviation (ps)	Dispersion (ps/nm)	Dispersion (ps/(nm.km))
<input checked="" type="checkbox"/>	1535.0	0.00	-0.662	0.662	53.129	53.129
<input checked="" type="checkbox"/>	1550.0	987.12	987.315	0.193	78.602	78.602
<input checked="" type="checkbox"/>	1565.0	1841.98	2357.388	515.403	104.075	104.075
<input checked="" type="checkbox"/>	1580.0	4100.27	4109.557	9.290	129.548	129.548
<input checked="" type="checkbox"/>	1595.0	6251.35	6243.823	7.527	155.021	155.021
<input checked="" type="checkbox"/>	1610.0	8757.82	8760.186	2.368	180.494	180.494

Fiber ID: LEAF2 Averaging Time: 4.0 s
 Comment: Acquisition Date: 2002-08-15 16:47:12
 RGD Weighted RMS Error: 120.066 ps Reference Date: 2002-08-15 14:44:20
 Receiver Source
 Model:
 Serial Number:
 2003-09-19 11:53

If you want to lower your RGD's mean square error rate, you can remove the points with a larger RGD deviation from the graph. This way, they will no longer be taken into account when applying the fit. As soon as you remove one point, the RGD, fitted RGD, RGD deviation, dispersion and coefficient of dispersion are recalculated.

Note: *The points you remove will remain visible on the graph, but grayed out.*

If you want to remove acquisitions permanently, see *Keeping Track of Acquisitions* on page 54.

To automatically sort data:

In the results table, select the column header corresponding to the criterion you want to use to sort data.

Managing Results

Keeping Track of Acquisitions

To select or deselect points:

Select or deselect the corresponding boxes in the first column of the results table.

Keeping Track of Acquisitions

The application offers a general view of both the current acquisitions and those from a reloaded file. When a problem occurs, such as a fiber break, you may want to delete the corresponding erroneous measurement. This could be useful to avoid distorting results. The removal will only be effective if you save changes (see *Saving Your Results* on page 39). If you want to discard the changes, simply answer “No” when the application will prompt you to save the file.

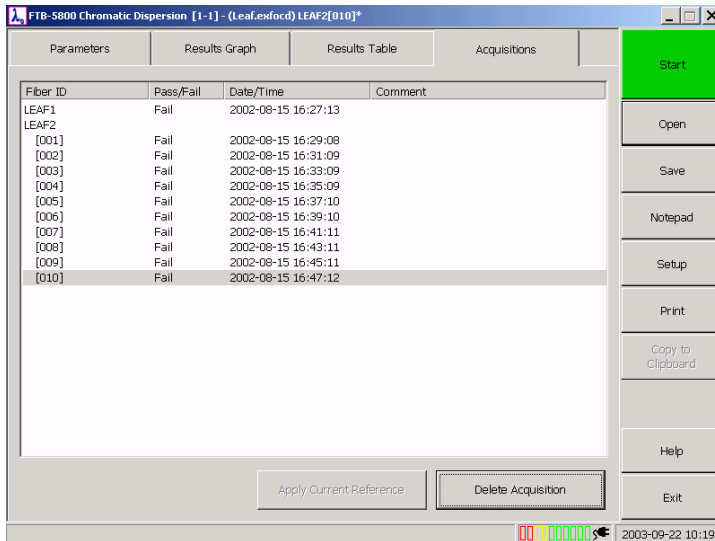

To display an overall view of the results:

Click the **Acquisitions** tab.

To delete unwanted results:

- 1.** In the provided list, select the acquisition to be deleted and click **Delete Acquisition**.
- 2.** A confirmation message will be displayed. Click **Yes** to confirm.
- 3.** Repeat steps 1 and 2 for each acquisition you want to delete.



Managing Results

Establishing Thresholds

Establishing Thresholds

You can establish two types of thresholds: the dispersion and slope 0 thresholds.

The **Dispersion Threshold** will be displayed when the fiber you test surpasses the dispersion level you allowed. It is applied to every wavelength and will be displayed in the **Results Table** tab, where you will have three possible results:

-  if your acquisition did not exceed the specified threshold.
-  if your acquisition exceeded the specified threshold.
- --- if there are not enough points to calculate the fit or for the dispersion per kilometer if the fiber length is unknown.

Note: Symbols are only displayed if you have selected a threshold.

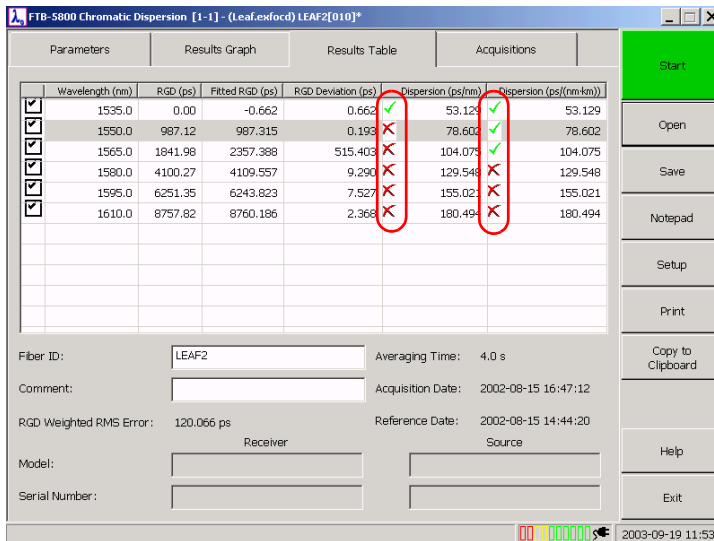

Wavelength (nm)	RGD (ps)	Fitted RGD (ps)	RGD Deviation (ps)	Dispersion (ps/nm)	Dispersion (ps/(nm-km))		
1535.0	0.00	-0.662	0.662	✓	53.129	✓	53.129
1550.0	987.12	987.315	0.193	✗	78.602	✓	78.602
1565.0	1841.98	2357.388	515.403	✗	104.075	✓	104.075
1580.0	4100.27	4109.557	9.290	✗	129.548	✗	129.548
1595.0	6251.35	6243.823	7.527	✗	155.021	✗	155.021
1610.0	8757.82	8760.186	2.368	✗	180.494	✗	180.494

Fiber ID: LEAF2 Averaging Time: 4.0 s
Comment: Acquisition Date: 2002-08-15 16:47:12
RGD Weighted RMS Error: 120.066 ps Reference Date: 2002-08-15 14:44:20
Receiver Source
Model:
Serial Number:
2003-09-19 11:53

The **Slope 0 Threshold** is the slope of the dispersion curve evaluated at the points where the dispersion is null (λ_0). In the **Results Graph** tab, you will have four possible results:

- **Pass** if the slope at λ_0 is less than or equal to the threshold.
- **Fail** if it is greater than the threshold.
- **Fit** if your slope at λ_0 did not respect FOTP standard 169. This standard requires other points within 100 nm; otherwise, the slope at λ_0 is not reliable and can only be used as a reference.
- --- if you did not select any thresholds.

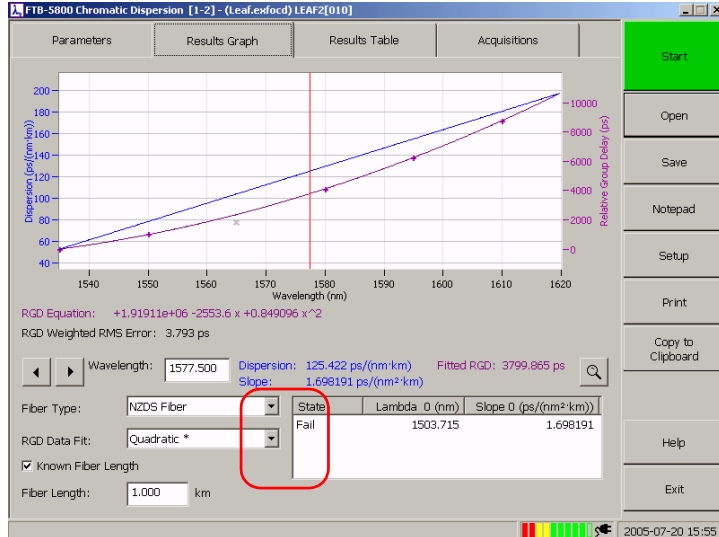

Managing Results

Establishing Thresholds

To establish your thresholds:

1. On the button bar, click **Setup**.
2. Set the thresholds as required.

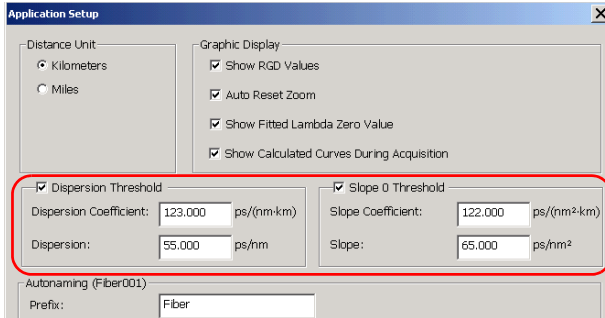

The screenshot shows the 'Application Setup' dialog box. It has several sections: 'Distance Unit' with radio buttons for 'Kilometers' (selected) and 'Miles'; 'Graphic Display' with checked options for 'Show RGD Values', 'Auto Reset Zoom', 'Show Fitted Lambda Zero Value', and 'Show Calculated Curves During Acquisition'; 'Dispersion Threshold' with checked 'Dispersion Threshold' and input fields for 'Dispersion Coefficient' (123.000 ps/(nm·km)) and 'Dispersion' (55.000 ps/nm); 'Slope 0 Threshold' with checked 'Slope 0 Threshold' and input fields for 'Slope Coefficient' (122.000 ps/(nm²·km)) and 'Slope' (65.000 ps/nm²); and 'Autonaming (Fiber001)' with a 'Prefix' field containing 'Fiber'. A red rectangle highlights the threshold settings section.

- If you want to establish a dispersion threshold, select the **Dispersion Threshold** check box and enter the values in the appropriate boxes.
 - If you want to establish a slope 0 threshold, select the **Slope 0 Threshold** check box and enter the values in the appropriate boxes.
3. When you are done, click **OK**.

Documenting Results

For easier management, you may want to add comments and information about the tests that were performed. It is possible to include general and specific information.

General information concerns jobs, receiver and source. Specific information is related to measurements. This information could be included later in reports or in exported ASCII files.

To add general information:

1. On the button bar, click **Notepad**.

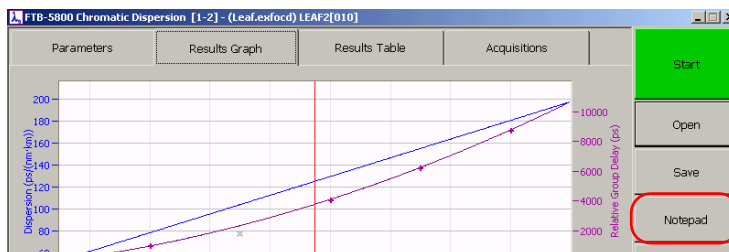

2. In **Notepad**, fill the boxes according to your needs.

3. When you are done, click **OK**.

Managing Results

Documenting Results

To add specific information:

1. On the **Acquisitions** tab, select the acquisition you wish to comment (the row must be highlighted).

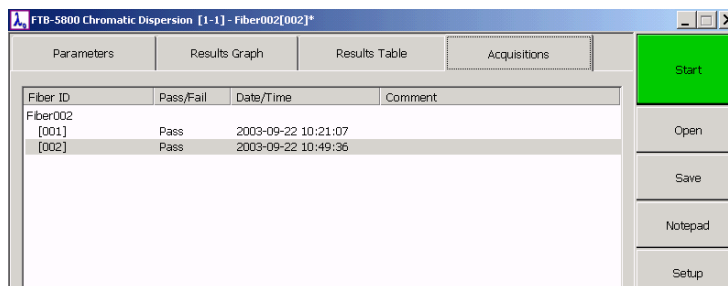

2. On the **Results Table**, fill in the **Comments** box.

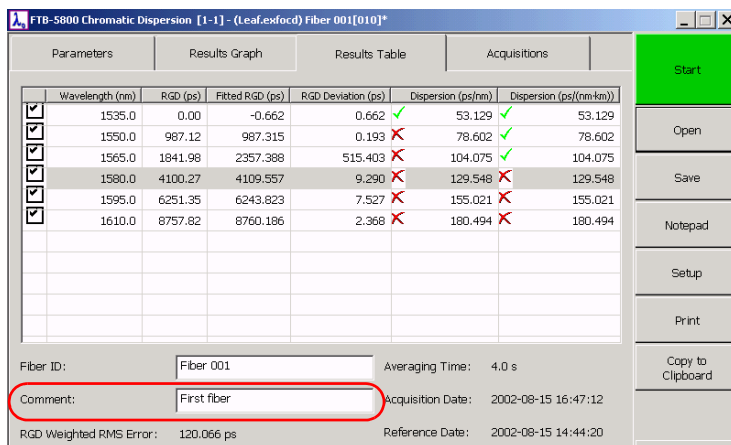

The modifications will only be effective if you save them (see *Saving Your Results* on page 39). If you want to discard the changes, simply answer “No” when the application will prompt you to save the file.

Exporting Results and Graphs to Clipboard

The FTB-5800 Chromatic Dispersion Analyzer offers you the possibility of quickly building your own reports by copying results and graphs to the clipboard. Afterwards, the content of the clipboard can be pasted onto a word-processor document of your choice. Graphs are exported exactly as you see them on the screen (zoom factor and display are kept) and converted to .bmp format.

Note: *Only the points that are selected on the **Results Table** tab will be exported.*

If you prefer to work with raw data to build your own tables and graphs, see *Exporting CD Analyzer Files with the File Export Tool* on page 65.



IMPORTANT

Since information is stored to the clipboard, you cannot export both results and graph simultaneously. You must copy them one at a time.

To export the results table to the clipboard:

1. On the **Results Table** tab, ensure that all the points you want to export are selected (the box appearing in the first column is checked).
2. On the button bar, click **Copy to Clipboard**.

You can now paste the content of the clipboard onto a word-processor document, for example.

To export the graph to the clipboard:

1. On the **Results Table** tab, ensure that all the points you want to export are selected (the check box appearing in the first column is selected).
2. Click the **Results Graph** tab.
3. On the button bar, click **Copy to Clipboard**.

You can now paste the content of the clipboard onto a word-processor document, for example.

Printing Results

The Chromatic Dispersion Analyzer allows you to print reports containing test information and results. You can customize the report's content by selecting the sections, their order of appearance, as well as the acquisitions that will be included. In fact, it is possible to print reports including all the acquisitions listed on the **Acquisitions** tab or only the current one.

To print a report:

1. On the button bar, click **Print**.
2. Specify which sections must appear in the report by selecting and clearing the corresponding check boxes.

Note: *The **Select All** and **Clear All** buttons allow you to quickly add/remove selections.*

3. If necessary, rearrange the order of the sections in the report:
 - 3a. Select the section you want to move (ensure that the corresponding line is highlighted).
 - 3b. Click the **Move Up** and **Move Down** buttons.

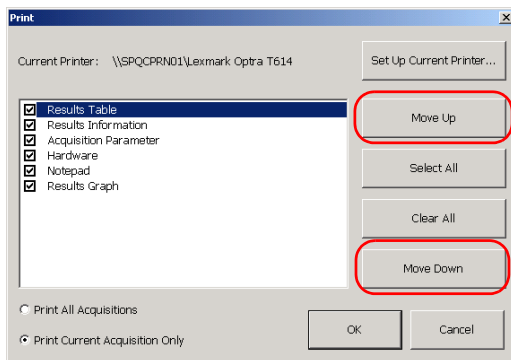

- 3c. Repeat steps 3a and 3b for each section you want to move.

4. Select **Print All Acquisitions** or **Print Current Acquisition Only**, depending on the type of report you need.

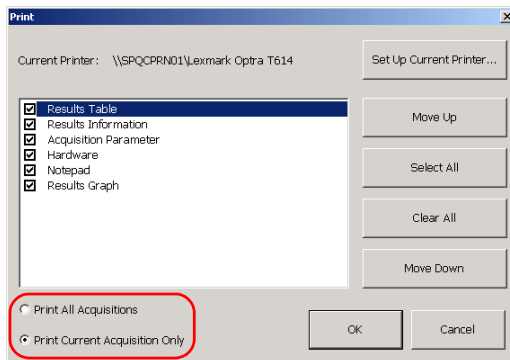

5. If necessary, set the printer parameters by using the **Set Up Current Printer** button.
6. When you are done, click the **OK** button to start printing.

6 **Exporting CD Analyzer Files with the File Export Tool**

The File Export tool has been designed to export chromatic dispersion files to specific formats:

- text files
- comma-delimited (.csv) files

You can also fully customize the contents of the generated files by exporting only the information you need.

Starting and Exiting the File Export Tool

To start the export tool:

1. From the main window, select the Applications tab

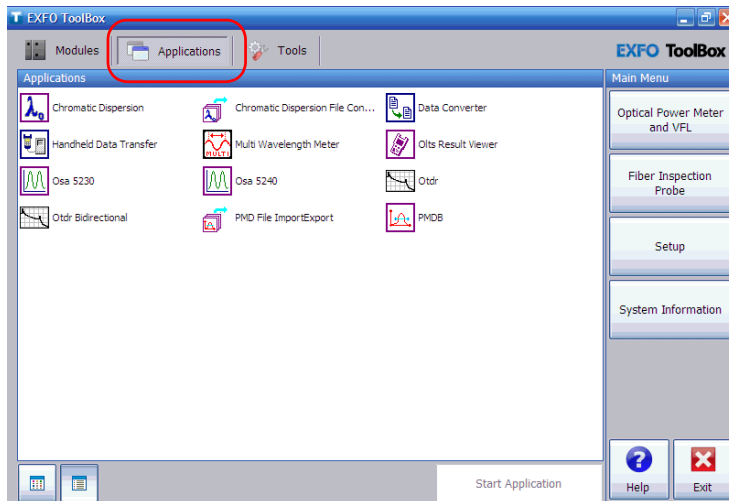

2. Select **Chromatic Dispersion File Converter**.
3. Press **Start Application**.

Exporting CD Analyzer Files with the File Export Tool

Starting and Exiting the File Export Tool

The File Export tool main window is displayed.

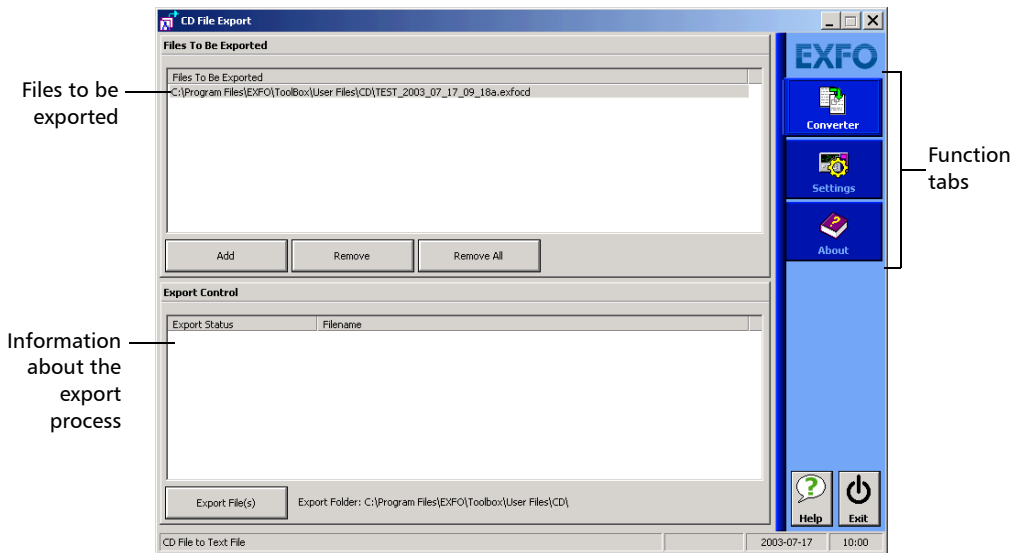

To exit the export tool:

- Click  (in the top right corner of the main window).
- Click the **Exit** button located at the bottom of the function tabs bar.

Setting Export Parameters

Before exporting data in one format to another, you must define:

- Which information must be exported: You can export general test information (fiber ID, acquisition parameters, source and receiver information, etc.) as well as points from the acquired traces. This is particularly useful if you intend to build your own graphs using Microsoft Excel, for instance.
- The conversion type (to text or to comma-delimited format).
- Where to export files.

The parameters you set will remain unchanged until you choose to modify them. They will still be available after the FTB-500 Universal Test Platform (or the computer) has shut down.

Exporting CD Analyzer Files with the File Export Tool

Setting Export Parameters

To set export parameters:

1. If necessary, open the File Export tool (see *Starting and Exiting the File Export Tool* on page 65).
2. Select the desired conversion type.

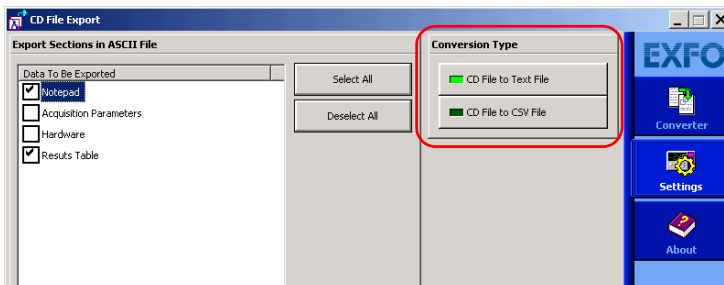

Exporting CD Analyzer Files with the File Export Tool

Setting Export Parameters

3. On the **Settings** function tab, select all the check boxes corresponding to the information you want to export.

Note: *If you select **Results Table**, all points acquired during the test will be exported.*

4. Under **Export Folder**, click **Browse** to specify in which folder the exported files will be stored.

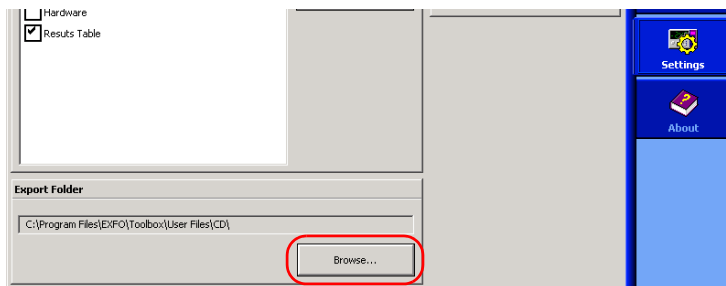

Exporting Chromatic Dispersion Files

Once the export parameters are set, you are now ready to start exporting your files. Files that cannot be exported (for example, files already open in another application or corrupt files) will be skipped and their export status will change to “*Failed*”.



IMPORTANT

To avoid errors during file export, ensure that all the files you intend to use are closed.

To export chromatic dispersion files:

1. If necessary, start the export tool (see *Starting and Exiting the File Export Tool* on page 65).
2. If necessary, set the export parameters (see *Setting Export Parameters* on page 67).
3. Click the **Converter** function tab of the File Export tool.

Exporting CD Analyzer Files with the File Export Tool

Exporting Chromatic Dispersion Files

4. Select the files.

4a. Under **Files To Be Exported**, click **Add**.

A standard **Open** dialog box is displayed, allowing you to select the desired files.

Note: *You can speed up file selection by selecting several files at the same time.*

4b. When you are done, in the dialog box, click **Open** to transfer the files to the list.

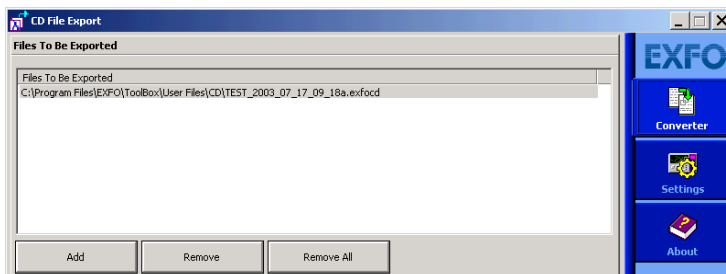

Note: *You can remove a specific file by selecting it and using **Remove**. If you want to quickly empty the list, select **Remove All**.*

5. Under **Export Control**, start the export process using the **Export File(s)** button.

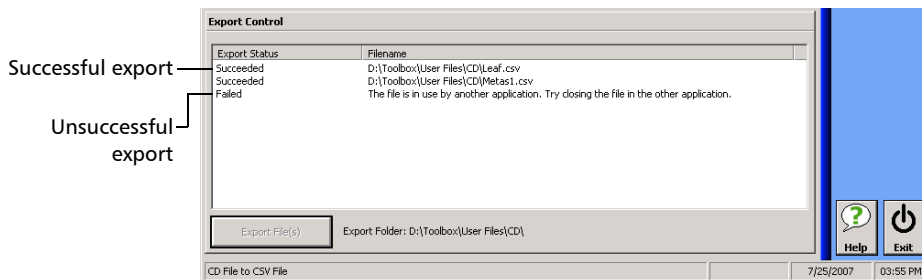

7 **Maintenance**

To help ensure long, trouble-free operation:

- Always inspect fiber-optic connectors before using them and clean them if necessary.
- Keep the unit free of dust.
- Clean the unit casing and front panel with a cloth slightly dampened with water.
- Store unit at room temperature in a clean and dry area. Keep the unit out of direct sunlight.
- Avoid high humidity or significant temperature fluctuations.
- Avoid unnecessary shocks and vibrations.
- If any liquids are spilled on or into the unit, turn off the power immediately and let the unit dry completely.



WARNING

Use of controls, adjustments, and procedures for operation and maintenance other than those specified herein may result in hazardous radiation exposure.

Cleaning EUI Connectors

Regular cleaning of EUI connectors will help maintain optimum performance. There is no need to disassemble the unit.



IMPORTANT

If any damage occurs to internal connectors, the module casing will have to be opened and a new calibration will be required.

To clean EUI connectors:

1. Remove the EUI from the instrument to expose the connector baseplate and ferrule.

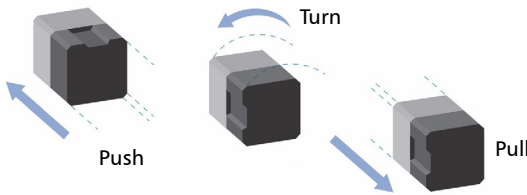

2. Moisten a 2.5 mm cleaning tip with *one drop* of isopropyl alcohol (alcohol may leave traces if used abundantly).
3. Slowly insert the cleaning tip into the EUI adapter until it comes out on the other side (a slow clockwise rotating movement may help).

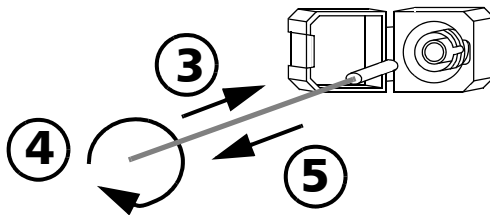

4. Gently turn the cleaning tip one full turn, then continue to turn as you withdraw it.

5. Repeat steps 3 to 4 with a dry cleaning tip.

Note: *Make sure you don't touch the soft end of the cleaning tip.*

6. Clean the ferrule in the connector port as follows:

6a. Deposit *one drop* of isopropyl alcohol on a lint-free wiping cloth.



IMPORTANT

Isopropyl alcohol may leave residues if used abundantly or left to evaporate (about 10 seconds).

Avoid contact between the tip of the bottle and the wiping cloth, and dry the surface quickly.

- 6b.** Gently wipe the connector and ferrule.
- 6c.** With a dry lint-free wiping cloth, gently wipe the same surfaces to ensure that the connector and ferrule are perfectly dry.
- 6d.** Verify connector surface with a portable fiber-optic microscope (for example, EXFO's FOMS) or fiber inspection probe (for example, EXFO's FIP).



WARNING

Verifying the surface of the connector WHILE THE UNIT IS ACTIVE WILL result in permanent eye damage.

7. Put the EUI back onto the instrument (push and turn clockwise).
8. Throw out cleaning tips and wiping cloths after one use.

Recalibrating the Unit

Manufacturing and service center calibrations are based on the ISO/IEC 17025 Standard, which states that calibration documents must not contain a recommended calibration interval, unless this has been previously agreed upon with the customer.

Validity of specifications depends on operating conditions. For example, the calibration validity period can be longer or shorter depending on the intensity of use, environmental conditions and unit maintenance. You should determine the adequate calibration interval for your unit according to your accuracy requirements.

Under normal use, EXFO recommends calibrating your unit every year.

Recycling and Disposal (Applies to European Union Only)



Recycle or dispose of your product (including electric and electronic accessories) properly, in accordance with local regulations. Do not dispose of it in ordinary garbage receptacles.

This equipment was sold after August 13, 2005 (as identified by the black rectangle).

- Unless otherwise noted in a separate agreement between EXFO and a customer, distributor, or commercial partner, EXFO will cover costs related to the collection, treatment, recovery, and disposal of end-of-lifecycle waste generated by electronic equipment introduced after August 13, 2005 to an European Union member state with legislation regarding Directive 2002/96/EC.
- Except for reasons of safety or environmental benefit, equipment manufactured by EXFO, under its brand name, is generally designed to facilitate dismantling and reclamation.

For complete recycling/disposal procedures and contact information, visit the EXFO Web site at www.exfo.com/recycle.

8 Troubleshooting

Solving Common Problems

Fatal Error	Consequences	Recommended Solution
Module temperature is too high for operation.	The module will stop functioning.	Use the system within the recommended operation temperature. ^a
Module temperature is too low for operation.	The module will stop functioning.	Use the system within the recommended operation temperature. ^a
There is a critical module error.	The module will stop functioning.	Try restarting the application. If the problem persists, contact EXFO.

a. See *Technical Specifications* on page 89.

Operating Error	Consequences	Recommended Solution
Source power is too high.	The reference or acquisition will not be permitted.	<ul style="list-style-type: none"> ➤ Check if you have the right input port. ➤ Check if there is an amplifier in your fiber link. ➤ Use the intensity meter to check the source's signal. ➤ Add an attenuator to the link.
Source power is too low.	The reference or acquisition will not be permitted.	<ul style="list-style-type: none"> ➤ Check if the fiber link is damaged. ➤ Use the intensity meter to check the source signal. ➤ Check your connections. ➤ Make sure your fiber link is not too long.

Troubleshooting

Solving Common Problems

Warning	Consequences	Recommended Solution
Source power is low.	Some points will be grayed out on the graph.	<ul style="list-style-type: none">➤ Check if you have the right input port.➤ Check if the fiber link is damaged.➤ Check for irregularities in the fiber.➤ Use the intensity meter to check the source's signal.➤ Make sure your fiber link is not too long.
The power of the source is too high.	Some points will be grayed out on the graph.	<ul style="list-style-type: none">➤ Use the intensity meter to check the source signal.➤ Check for irregularities in the fiber.
Module temperature is very high.	The accuracy of your measurements can be affected.	Use the system within the recommended operation temperature. ^a
Module temperature is very low.	The accuracy of your measurements can be affected.	Use the system within the recommended operation temperature. ^a

a. See *Technical Specifications* on page 89.

Viewing Online Documentation

An online version of the FTB-5800 Chromatic Dispersion Analyzer user guide is available at all times from the application.

To access the online user guide:

Click **Help** in the function bar.

Troubleshooting

Contacting the Technical Support Group

Contacting the Technical Support Group

To obtain after-sales service or technical support for this product, contact EXFO at one of the following numbers. The Technical Support Group is available to take your calls from Monday to Friday, 8:00 a.m. to 7:00 p.m. (Eastern Time in North America).

For detailed information about technical support, visit the EXFO Web site at www.exfo.com.

To accelerate the process, please have information such as the name and the serial number (see the product identification label—an example is shown below), as well as a description of your problem, close at hand.

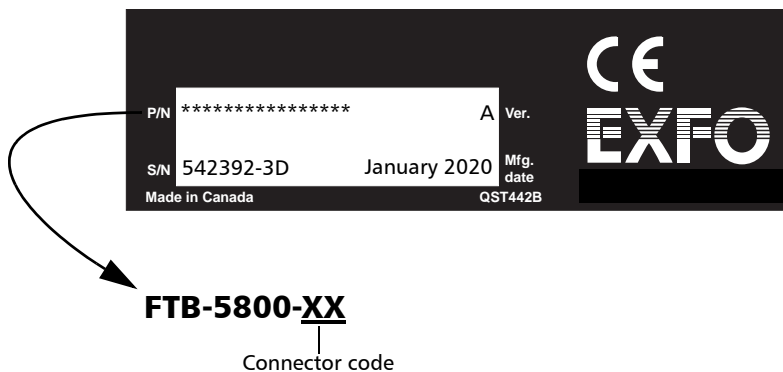

Transportation

Maintain a temperature range within specifications when transporting the unit. Transportation damage can occur from improper handling. The following steps are recommended to minimize the possibility of damage:

- Pack the unit in its original packing material when shipping.
- Avoid high humidity or large temperature fluctuations.
- Keep the unit out of direct sunlight.
- Avoid unnecessary shocks and vibrations.

9 **Warranty**

General Information

EXFO Electro-Optical Engineering Inc. (EXFO) warrants this equipment against defects in material and workmanship for a period of one year from the date of original shipment. EXFO also warrants that this equipment will meet applicable specifications under normal use.

During the warranty period, EXFO will, at its discretion, repair, replace, or issue credit for any defective product, as well as verify and adjust the product free of charge should the equipment need to be repaired or if the original calibration is erroneous. If the equipment is sent back for verification of calibration during the warranty period and found to meet all published specifications, EXFO will charge standard calibration fees.



IMPORTANT

The warranty can become null and void if:

- **unit has been tampered with, repaired, or worked upon by unauthorized individuals or non-EXFO personnel.**
- **warranty sticker has been removed.**
- **case screws, other than those specified in this guide, have been removed.**
- **case has been opened, other than as explained in this guide.**
- **unit serial number has been altered, erased, or removed.**
- **unit has been misused, neglected, or damaged by accident.**

THIS WARRANTY IS IN LIEU OF ALL OTHER WARRANTIES EXPRESSED, IMPLIED, OR STATUTORY, INCLUDING, BUT NOT LIMITED TO, THE IMPLIED WARRANTIES OF MERCHANTABILITY AND FITNESS FOR A PARTICULAR PURPOSE. IN NO EVENT SHALL EXFO BE LIABLE FOR SPECIAL, INCIDENTAL, OR CONSEQUENTIAL DAMAGES.

Warranty

Liability

Liability

EXFO shall not be liable for damages resulting from the use of the product, nor shall be responsible for any failure in the performance of other items to which the product is connected or the operation of any system of which the product may be a part.

EXFO shall not be liable for damages resulting from improper usage or unauthorized modification of the product, its accompanying accessories and software.

Exclusions

EXFO reserves the right to make changes in the design or construction of any of its products at any time without incurring obligation to make any changes whatsoever on units purchased. Accessories, including but not limited to fuses, pilot lamps, batteries and universal interfaces (EUI) used with EXFO products are not covered by this warranty.

This warranty excludes failure resulting from: improper use or installation, normal wear and tear, accident, abuse, neglect, fire, water, lightning or other acts of nature, causes external to the product or other factors beyond the control of EXFO.



IMPORTANT

EXFO will charge a fee for replacing optical connectors that were damaged due to misuse or bad cleaning.

Certification

EXFO certifies that this equipment met its published specifications at the time of shipment from the factory.

Service and Repairs

EXFO commits to providing product service and repair for five years following the date of purchase.

To send any equipment for service or repair:

1. Call one of EXFO's authorized service centers (see *EXFO Service Centers Worldwide* on page 87). Support personnel will determine if the equipment requires service, repair, or calibration.
2. If equipment must be returned to EXFO or an authorized service center, support personnel will issue a Return Merchandise Authorization (RMA) number and provide an address for return.
3. If possible, back up your data before sending the unit for repair.
4. Pack the equipment in its original shipping material. Be sure to include a statement or report fully detailing the defect and the conditions under which it was observed.
5. Return the equipment, prepaid, to the address given to you by support personnel. Be sure to write the RMA number on the shipping slip. *EXFO will refuse and return any package that does not bear number.*

Note: *A test setup fee will apply to any returned unit that, after test, is found to meet the applicable specifications.*

After repair, the equipment will be returned with a repair report. If the equipment is not under warranty, you will be invoiced for the cost appearing on this report. EXFO will pay return-to-customer shipping costs for equipment under warranty. Shipping insurance is at your expense.

Routine recalibration is not included in any of the warranty plans. Since calibrations/verifications are not covered by the basic or extended warranties, you may elect to purchase FlexCare Calibration/Verification Packages for a definite period of time. Contact an authorized service center (see *EXFO Service Centers Worldwide* on page 87).

EXFO Service Centers Worldwide

If your product requires servicing, contact your nearest authorized service center.

EXFO Headquarters Service Center

400 Godin Avenue
Quebec (Quebec) G1M 2K2
CANADA

1 866 683-0155 (USA and Canada)
Tel.: 1 418 683-5498
Fax: 1 418 683-9224
quebec.service@exfo.com

EXFO Europe Service Center

Omega Enterprise Park, Electron Way
Chandlers Ford, Hampshire S053 4SE
ENGLAND

Tel.: +44 2380 246810
Fax: +44 2380 246801
europe.service@exfo.com

EXFO China Service Center/ Beijing OSIC

Beijing New Century Hotel
Office Tower, Room 1754-1755
No. 6 Southern Capital Gym Road
Beijing 100044
P. R. CHINA

Tel.: +86 (10) 6849 2738
Fax: +86 (10) 6849 2662
beijing.service@exfo.com

A Technical Specifications



IMPORTANT

The following technical specifications can change without notice. The information presented in this section is provided as a reference only. To obtain this product's most recent technical specifications, visit the EXFO Web site at www.exfo.com.

SPECIFICATIONS ^a

Wavelength range (nm)		1530 to 1625		
		1200 to 1700 ^b		
Wavelength step (nm)	Minimum	0.1		
Measurement points	Maximum	950, user-definable		
Dynamic range ^c (dB)		42		
Wavelength uncertainty ^d (accuracy) (nm)		0.1		
Dispersion uncertainty ^d (accuracy) (ps/nm)	20 km of G.652	1.6		
	120 km of G.652	3.1		
	20 km of G.655	1.9 (guaranteed)		
		20 km	80 km	120 km
Dispersion repeatability ^d (ps/nm)		0.04	0.2	1.1
Zero-dispersion wavelength λ_0 repeatability ^d (nm)		0.1	0.14	0.8
Dispersion slope repeatability λ_0 ^d (%)		0.03	0.05	0.25
Minimum fiber length (km)		< 1		
Maximum fiber length ^e (km)		> 5400		
Measurement time per point ^e (s)	Minimum	< 1		

Notes

- All specifications are typical with four seconds averaging time per point (where applicable), at a temperature of 23 °C ± 1 °C, with FC connectors and after warmup time.
- Displayed range. Values may be extrapolated.
- Dynamic range is defined as the difference between the strongest signal and the weakest signal the receiver can detect. Extra averaging may be required. Uncertainty (accuracy) is not guaranteed at limits of range.
- C+L band.
- Including EDFAs.
- Additional gain setting time may be required prior to the first point of each band.

GENERAL SPECIFICATIONS

Size (H x W x D) (module)	9.6 cm x 10 cm x 26 cm	(3 ³ / ₄ in x 3 ¹⁵ / ₁₆ in x 10 ¹ / ₄ in)
Weight (module)	2 kg	(4.5 lb)

B *Measuring Chromatic Dispersion: Theory*

EXFO's Chromatic Dispersion Analyzer applies the phase-shift method, which consists of measuring the phase variation of a sinusoidal intensity modulated signal at a specific wavelength to obtain the relative group delay of a fiber. The derivative of the relative group delay calculated from fitted equations on computed results gives the dispersion, the zero-dispersion wavelength and the dispersion slope.

Method Behind the Chromatic Dispersion Analyzer

In EXFO's Chromatic Dispersion Analyzer, the light source is a broadband source, which is intensity modulated at a high frequency. This light is injected into the fiber under test and the modulated light travels along the fiber. The high-frequency intensity modulation propagates at a speed that depends on wavelength and polarization. Values are obtained for the differences in travel time between modulation at different wavelengths. The higher the number of wavelengths at which this is done, the more accurate the chromatic dispersion results will be.

The first fixed filter in the receiver extracts the portion of the light that will follow an optical path. A second filter, which is a time-tunable filter, will extract a second part of the original signal and then follow a different optical path.

Different path combinations are added using a chopper. The amplitude of the high-frequency signals are measured and digitized. The phase difference is then computed using the different amplitudes. This value is stored along with the tunable filters position and a new measurement cycle begins. A new time delay is computed and stored with wavelength data. When sufficient data is accumulated, chromatic dispersion can be computed.

Measuring Chromatic Dispersion: Theory

Using Data Fits to Obtain Dispersion

Using Data Fits to Obtain Dispersion

This section gives you details about the way EXFO uses the data fits to obtain dispersion. Once group delays are computed, equations are fitted in order to obtain dispersion, dispersion slope and zero-dispersion wavelengths. The dispersion curve of typical singlemode fibers follows certain equations used to interpolate zero-dispersion wavelength and slope. The following table graph shows the equations applied to singlemode fibers in specific wavelength ranges.

Fiber Type and Wavelength Range	Expression for D
Standard SM 1200 nm ≤ λ ≤ 1600 nm	$\tau(\lambda) = A + B\lambda^2 + C\lambda^{-2}$ $D(\lambda) = 2(B\lambda - C\lambda^{-3})$
Dispersion-shifted 1500 nm-1600 nm	$\tau(\lambda) = A + B\lambda^2 + C\lambda$ $D(\lambda) = 2B\lambda + C$
Non-zero dispersion-shifted up to 1560 nm	$D(\lambda) = \left\{ \left[\frac{D(1560) - D(1530)}{30} \right]^\circ \cdot (\lambda - 1560) \right\} + D(1560)$
Non-zero dispersion-shifted 1530 nm-1565 nm (C Band) 1565 nm-1625 nm (L Band)	$D(\lambda) = \left\{ \left[\frac{D(1565) - D(1530)}{35} \right]^\circ \cdot (\lambda - 1565) \right\} + D(1565)$ $D(\lambda) = \left\{ \left[\frac{D(1625) - D(1565)}{60} \right]^\circ \cdot (\lambda - 1625) \right\} + D(1625)$
Dispersion-shifted 1200 nm ≤ λ ≤ 1600 nm	$\tau(\lambda) = A + B\lambda + C\lambda \ln(\lambda)$ $D(\lambda) = B + C + C \ln(\lambda)$

Fiber Type and Wavelength Range	Expression for D
50/125 $50\text{nm} \leq \lambda \leq 1450\text{nm}$	$\tau(\lambda) = A + B\lambda^2 + C\lambda^{-2}$ $D(\lambda) = 2(B\lambda - C\lambda^{-3})$
62.5/125 $750\text{nm} \leq \lambda \leq 1450\text{nm}$	$\tau(\lambda) = A + B\lambda^2 + C\lambda^{-2}$ $D(\lambda) = 2(B\lambda - C\lambda^{-3})$
Non-zero dispersion-shifted 1530 nm-1565 nm	$D(\lambda) = \left\{ \left[\frac{D(1565) - D(1530)}{35} \right] \cdot (\lambda - 1565) \right\} + D(1565)$

As the previous table demonstrates, specific fits are recommended for specific types of fiber and specific wavelength ranges. Fits should be used carefully when extrapolating parameters to obtain maximum precision.

- The 3-Term Sellmeier applies mostly to standard fibers with single zero dispersion at 1300 nm.
- The 5-Term Sellmeier has five zero crossings. Since it is extremely elastic, it should be used with caution when extrapolating because the fit may curve away from the true results beyond fitted points.
- The same warning applies to the cubic fit.
- The lambda-log-lambda fit is applicable to dispersion-shifted fibers with a zero dispersion wavelength in the 1550 nm wavelength region.
- The linear fit is useful when there are too few measurements for multiple parameter fits to be used. It is applicable to all fibers if the range is sufficiently small.

The fits will give you a tool to obtain the dispersion slope and zero-dispersion point.

Helping You Manage Chromatic Dispersion

The zero-dispersion wavelength (where dispersion is at zero) corresponds to the wavelength point at which the fiber under test reaches its maximum bandwidth. The slope from this zero-dispersion point indicates how fast dispersion rises as wavelength increases. Key chromatic dispersion parameters are the dispersion zero and the slope at zero dispersion.

Getting precise chromatic dispersion parameters helps you select the right dispersion-compensated fiber or material in order to reverse the dispersion and dispersion slope before the data is interpreted by the receiver at the other end of the line.

The effects of chromatic dispersion decrease with a reduction in the absolute value of the fiber chromatic dispersion or with dispersion compensation.

Index

A	
accessing File Export	65
accuracy, results	28
acquiring multiple traces	35
acquisition, stopping	37
after-sales service	80
application	
exiting	12
File Export	65
starting, single-module	9
applying fits, precautions for	44
ASCII files, generating	65
automatic names for fibers	20
averaging time	
definition	16
strong signal	16
using preprogrammed times	16
weak signal	16
B	
bands	
C	13
C+L	13
L	13
referencing	28
Busy, module status	12
C	
calibration	
certificate	75
interval	75
caution	
of personal hazard	4
of product hazard	4
CD analyzer, internal design of	91
certification information	v
choosing the right wavelength step	15
chromatic dispersion	
definition	3
factors	94
managing	94
measuring	37
reference	28
taking a reference	31
cleaning	
detector ports	74
EUI connectors	72
fiber ends	24
front panel	71
clipboard, exporting results to	61
connectors, cleaning	72
conventions, safety	4
converting files	65
copying results to clipboard	61
creating a file	34
csv files	65
customer service	86
D	
defining fiber name	20
detecting module	7
detector port, cleaning	74
dispersion curve	43
distance units, modifying	19
documenting results	59
DUT, naming	20
E	
entering fiber length	18
equipment returns	86
establishing thresholds	56
EUI	
connector adapter	23
dust cap	23
EUI connectors, cleaning	72

Index

exiting application..... 12, 65
exporting
 chromatic dispersion files 65
 results..... 61

F

fiber ends, cleaning..... 24
fiber length known/unknown..... 17
fiber name format, defining..... 20
fiber type fit
 default..... 18
 for link of more than one type..... 18
 for unknown fiber type link..... 18
File Export, accessing/quitting..... 65
files
 creating..... 34
 exporting..... 65
 format of..... 65
fits
 3-Term Sellmeier..... 93
 5-Term Sellmeier..... 93
 cubic..... 93
 equations..... 92
 lambda log lambda 93
 linear 93
format, file..... 65
front panel, cleaning..... 71

H

help. see online user guide

I

identification label 80
identification, slot..... 11
inserting a module..... 5
intensity meter 27
intensity of the source..... 27
interval between acquisitions..... 35

L

label, identification..... 80

M

main window 11
maintenance
 detector ports..... 74
 EUI connectors..... 72
 front panel..... 71
 general information 71
marker
 positioning..... 48
 utility 44, 48
measurement, reference..... 28
module
 detection 7
 insertion..... 5
 removal..... 5
 status 12
module position 11
mounting EUI connector adapter 23
multiple measurements 35

N

naming fibers 20
notepad
 filling additional information 59
 function 59

O

online user guide..... 79
opening a saved file 42

P

parameters, printer..... 63
PDF. see online user guide
performance, optimum 28
phase-shift method 1
position, module 11

printing		
arranging report presentation	62	
setup parameters	63	
product		
identification label	80	
specifications	89	
protective cap	74	
pulse broadening, causes of	3	
R		
Ready, module status	12	
recalibration	75	
reference		
applying, after acquisition	33	
chromatic dispersion	31	
frequency	28	
low-CD measurement	28	
taking	28	
wavelength	29	
relative group delay curve	43	
relative group delay points	43	
removing a module	5	
report, sections order	62	
results		
accuracy	28	
applying different fit	44	
documenting	59	
graph	43	
viewing with external application	61	
zooming	49	
return merchandise authorization (RMA)	86	
S		
safety		
caution	4	
conventions	4	
warning	4	
saved file, opening	42	
saving results	38	
sections in report, order of	62	
service and repairs	86	
service centers	87	
setting averaging time		
using custom option	16	
setting wavelength range		
using custom option	13	
using preset bands	13	
setting wavelength step		
using custom option	15	
using preset steps	14	
shipping to EXFO	86	
slot number	11	
software. see application		
source		
bandwidth	27	
connection	27	
model	32	
power	27	
serial number	32	
specifying model	32	
specifying serial number	32	
source intensity	27	
specifications, product	89	
starting		
acquisition	37	
software	65	
starting application	65	
status bar	12	
stopping an acquisition	37	
storage requirements	71	
symbols, safety	4	
T		
technical specifications	89	
technical support	80	
temperature for storage	71	
test, adding general information about	59	
threshold		
dispersion	56	
slope 0	57	
time between acquisitions	35	
title bar	11	

Index

traces, acquiring many	35
transportation requirements	71, 81

U

unit recalibration.....	75
user guide. see online user guide	

V

verifying	
source bandwidth.....	27
source connection	27
source power.....	27

W

warranty	
certification	85
exclusions	85
general	83
liability.....	84
null and void.....	83
wavelength	
available bands.....	13
lower-range limit	13
reference	28
step	14
upper-range limit.....	13
wavelength scale.....	43
wavelength, taking a reference	29

Z

zero-dispersion wavelength, definition	94
zooming.....	49

NOTICE

通告

CHINESE REGULATION ON RESTRICTION OF HAZARDOUS SUBSTANCES

中国关于有害物质限制的规定

NAMES AND CONTENTS OF THE TOXIC OR HAZARDOUS SUBSTANCES OR ELEMENTS CONTAINED IN THIS EXFO PRODUCT



包含在本 EXFO 产品中的有毒有害物质或元素的名称和含量

O	Indicates that this toxic or hazardous substance contained in all of the homogeneous materials for this part is below the limit requirement in SJ/T11363-2006 表示该有毒有害物质在该部件所有均质材料中的含量均在 SJ/T11363-2006 标准规定的限量要求以下。
X	Indicates that this toxic or hazardous substance contained in at least one of the homogeneous materials used for this part is above the limit requirement in SJ/T11363-2006 表示该有毒有害物质至少在该部件的某一均质材料中的含量超出 SJ/T11363-2006 标准规定的限量要求。

Part Name 部件名称	Toxic or hazardous Substances and Elements 有毒有害物质和元素					
	Lead 铅 (Pb)	Mercury 汞 (Hg)	Cadmium 镉 (Cd)	Hexavalent Chromium 六价铬 (Cr VI)	Polybrominated biphenyls 多溴联苯 (PBB)	Polybrominated diphenyl ethers 多溴二苯醚 (PBDE)
Enclosure 外壳	O	O	O	O	O	O
Electronic and electrical sub-assembly 电子和电子组件	X	O	X	O	X	X
Optical sub-assembly ^a 光学组件 ^a	X	O	O	O	O	O
Mechanical sub-assembly ^a 机械组件 ^a	O	O	O	O	O	O

- a. If applicable.
聞種矽杉羽塞粒粒。

MARKING REQUIREMENTS
标注要求

Product 产品	Environmental protection use period (years) 环境保护使用期限 (年)	Logo 标志
This Exfo product 本 EXFO 产品	10	
Battery ^a 电池 ^a	5	

- a. If applicable.
閩種殆衫翎塞粒。

P/N: 1055210

www.EXFO.com · info@exfo.com

CORPORATE HEADQUARTERS	400 Godin Avenue	Quebec (Quebec) G1M 2K2 CANADA Tel.: 1 418 683-0211 · Fax: 1 418 683-2170
EXFO AMERICA	3701 Plano Parkway, Suite 160	Plano TX, 75075 USA Tel.: 1 972 907-1505 · Fax: 1 972 836-0164
EXFO EUROPE	Omega Enterprise Park, Electron Way	Chandlers Ford, Hampshire S053 4SE ENGLAND Tel.: +44 2380 246810 · Fax: +44 2380 246801
EXFO ASIA-PACIFIC	151 Chin Swee Road #03-29, Manhattan House	SINGAPORE 169876 Tel.: +65 6333 8241 · Fax: +65 6333 8242
EXFO CHINA	No. 88 Fuhua First Road, Central Tower, Room 801, Futian District Beijing New Century Hotel Office Tower, Room 1754-1755, No. 6 Southern Capital Gym Road	Shenzhen 518048 P. R. CHINA Tel.: +86 (755) 8203 2300 · Fax: +86 (755) 8203 2306 Beijing 100044 P. R. CHINA Tel.: +86 (10) 6849 2738 · Fax: +86 (10) 6849 2662

© 2009 EXFO Electro-Optical Engineering Inc. All rights reserved.
Printed in Canada (2009-03)

